

altuS VTR/DDR Controller
HT201, HT211, HT212

Users Manual

Software version: 2.0



History

Date	Description	Version
June 2007	altuS manual Version 1.0	1.0
June 2010	altuS manual revised	1.1

**Hi Tech Systems Ltd
Holbrook House
Oakley Lane
Oakley
Basingstoke
Hampshire RG23 7JY**

Tel: +44 (0) 1256 780880
Fax: +44 (0) 1256 782600
Email: support@hitechsys.com
Web: www.vtrcontrol.com
www.diskcontrol.com

The hardware/software and manual are copyright 1998 - 2010 by Hi Tech Systems Ltd. All rights reserved. The operating code is licensed by Hi Tech to the original purchaser only. It is not permitted to copy, sell or use this product in any other way than is intended.

All trademarks acknowledged.

According to the U.K. copyright law, unauthorised reproduction of software can be subject to civil damages.

The information in this document is subject to change without notice.

In no event will Hi Tech Systems Ltd be liable for direct, indirect, incidental or consequential damages resulting from any defect in the software even if they have been advised of such damages.

Contents

1 INTRODUCTION	1
2 INSTALLATION	3
Unpacking	3
Desk mounting	3
Warnings – read before installation or use	4
EXTERNAL CONNECTIONS	5
Power requirements	5
Connecting a VTR	6
RJ45 connector pin out	6
3 OPERATION	7
Using the main controller keys	7
How to Jog, shuttle and Var	8
How to record	8
How to stop record or playback	8
How to select both VTR channels for group control	9
Using Cues'	10
How to enter cue points	10
How to load cues	11
How to find and recall cue point	11
Description of display	12
What are the S keys?	12
How to store cue points to the S keys	12
How to recall a cue point using the S keys	13
Advanced Operations	13
How to loop a cue	13
How to do an auto cue	13
How to clear a single CUE memory location	14
How to clear the memory, and restore to factory default?	14
How to change the timecode source	15
Setting TCG and CTL	16
How to enter and exit the altuS SETUP menu.	17
How to change operational parameters in the SETUP menu	17
MENU OPERATIONAL SETTINGS	18
4 TROUBLE SHOOTING	23

ADDENDUM	24
SUMMARY OF FUNCTIONS	24
OUTLINE DIMENSIONS	25
SOFTWARE UPDATES	26
CABLE PIN OUT REFERENCE	27
NOTES ON PC SERIAL CONNECTORS	28
6 SPECIFICATION	30

1 Introduction

The Hi Tech altuS VTR/DDR controller provides a user-friendly remote control interface for professional broadcast videotape and disk recorders.

The controllers utilise a control wheel, called “smart χ wheel” that is our first implementation of Haptic technology – “Haptic” is Greek for the science of touch. Our controller can be programmed to give the operator different tactile and kinaesthetic sensations depending on the mode of operation, such as jog, indented incremental shuttle speeds and so on.

There are the three models:

altuS VTR and DDR Controllers



HT201 – single VTR controller no time code display.

HT211 – single VTR controller with time code display.

HT212 – dual VTR controller with time code display.

1 Introduction



This manual describes the operation of the HT212. Where differences in operation occur for the HT201 and HT211 it is noted like this:



Not on
the
HT201
or
HT211

Accessories supplied:

- 1 or 2 RJ45 to 9 pin 'D' type adaptors
- User's manual (this manual) on CD

Available options:

- Spare RJ45 to 9 pin 'D' type adaptor male for direct connection to VTR
- Spare RJ45 to 9 pin 'D' type adaptor female for connection to end of "standard" RS422 cable



In this manual altuS VTR and DDR controller is referred to as 'controller'. VTR and disk recorders are referred to as 'VTR'.

2 Installation

The Hi Tech Series of VTR Controllers are designed as desk-top units.

Unpacking

The Hi Tech Systems altuS VTR controllers are shipped in a carton which may contain other optional items within the packing. Care should be taken to ensure that these are not thrown away. The contents of the carton are as indicated on the delivery note. Carefully unpack and check for shipping damage and shortages. Report any damage or shortages to Hi Tech Systems Ltd.

Desk mounting

The altuS desk mounting controllers require no special fixings, but can be mounted into a desk as a 'drop through' unit.

Outline dimensions for all models are given in the Addendum at the back of this manual.

2 Installation

Warnings – read before installation or use



Only use the 12V adaptor provided with the controller. The 12V PSU is powered with 110V – 240V AC using an IEC main lead.

Only suitably qualified engineers should carry out maintenance.

Ensure that the power earth connection is correctly made.

Always check that the supply voltage specified is correct for the local AC power supply voltage.

The controller consists of electronic parts. Do not drop the controller or bump it against other objects or place the controller near heat sources such as radiators or air conditioning ducts.

Care should be taken so that solid objects or liquid do not fall into the Controller enclosure.

Clean the case with a soft dry lint free cloth, or a soft cloth lightly moistened with a mild detergent solution. Do not use any type of solvent such as alcohol, which might damage the special finish.

External connections

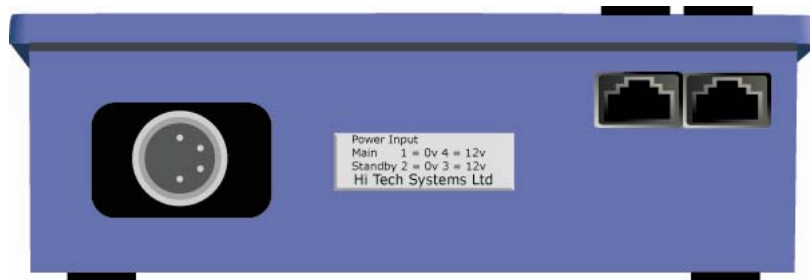

altuS rear view

Power requirements

In the UK, the mains plug should be approved to BS1363 and be fitted with a 3 amp fuse approved to BS1362.

All accessible metalwork in the room and the safety earth connections of other electrical circuits must be electrically connected together in accordance with safety regulations BS6204. This can be accomplished either by separate routes to the building earth or by bonding together or a combination of the two.

A suitable double-pole earth leakage protection device, conforming to BS6204, VDE0805 and IEC435 must be used to protect power supplied to the unit.

2 Installation

Connecting a VTR

The RS422 VTR control ports are implemented as RJ45 connectors to make the best use of space at the rear of a desk-top unit.



It is recommended not to exceed 100 metres of CAT 5 cable.

To convert RS422 ports on VTRs and other controlled devices to use RJ45 patch cables use the supplied converter

at the VTRs.

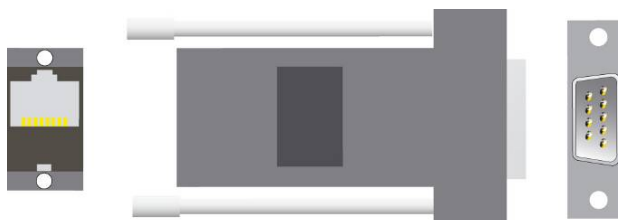

Converts VTR serial ports to RJ45

RJ45 connector pin out

Pin No	Description	RJ45 Connector
1	Chassis Gnd	<p>Chassis Connector</p> <p>Cable Connector</p> <p>View from front</p>
2	Rx A data	
3	Tx B data	
4	Tx Gnd	
5	N.C	
6	Rx Gnd	
7	Rx B data	
8	Tx A data	

CAT 5 VTR remote cables are connected to the RJ45 sockets

3 Operation



Using the main controller keys

To select a VTR for control, press the desired numbered channel selection key. The display will be updated with the timecode and transport status appropriate for the attached VTR.

The selected VTR **MUST** be enabled for remote control. If the VTR is set to operate locally from its own control panel then the controller will not function, only status will be displayed.

Once the controller has control of the VTR, the REMOTE LED will illuminate. If the VTR is switched into local, or the RS422 communications becomes

3 Operation

disconnected, the controller will sound several short warning 'bleeps' (if the bleeper has been turned ON in the menu) and the REMOTE LED will go off.

How to Jog, shuttle and Var

Press the wheel to enter JOG mode. Press again to go into shuttle. Press and hold the wheel to go into variable playback mode.



How to record

Press and hold the REC key and the PLAY key, the VTR will do a crash record.

How to stop record or playback

Press the blue stop key, this puts the VTR into STILL, press again to go into STOP mode. Press and hold the STOP key to turn "standby off".

How to select both VTR channels for group control

To select both VTRs for multiple controls,
press both selection keys at the same time.
To ungroup press both keys again.



The device selected first is treated as the Master and its status (e.g. PLAY, STOP etc) is shown in the display. If a different channel is then selected it now becomes the Master.



Not on
the
HT201
or
HT211

3 Operation

Using Cues'



For successful VTR cue operations the following conditions must be met:
Continuous time code or tape timer information from tape.
T/C key must be set for the same time code as on the VTR.

CUE locations are timecode reference points that have been stored in one or more of the controller's cue memory locations. There are 99 cue locations labelled 01 – 99 and an additional 5 "special" cue locations S1 – S5 (at memory locations 100 – 104). Once a cue is stored a VTR can be made to search very quickly to a selected CUE point.



Cue locations are not specific to VTR channels. If a cue is marked on one channel it simply goes into the next available location.

Each cue location is stored as an in point and / or out point. VTRs may be cued to any location. Cues are stored and recalled using the MARK IN, MARK OUT, CUE and S keys.

How to enter cue points



When first used the memory locations will be empty and indicated by --:--:--:-- but after time will become full. These will be overwritten by the new marked timecode.

A CUE IN point can be entered 'on the fly' whilst the tape is moving by pressing the MARK IN key, and a CUE OUT point can be similarly entered by pressing the MARK OUT key. The controller will always tell you the contents of the cue memory locations on the bottom line of the display.

The next cue memory location that will be used when you press MARK IN is displayed at the right hand end of the display. Location automatically increments every time a CUE is marked.

Note – Only a single Mark key on HT201 no mark out points can be stored.

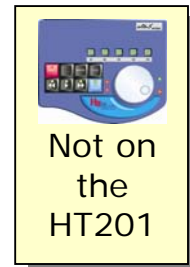

Mark In key

Mark Out key

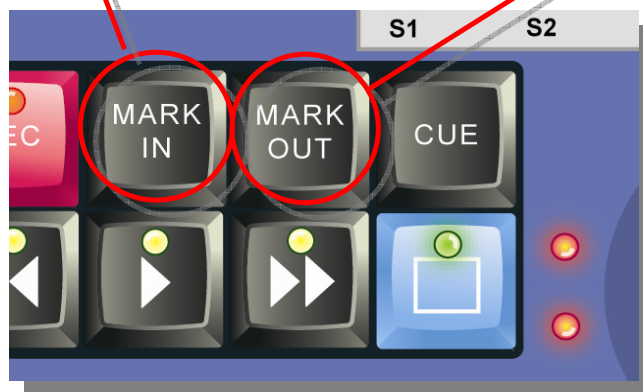

How to load cues

If CUE is pressed after a Mark has been made, then the VTR will cue directly to this mark.

How to find and recall cue point

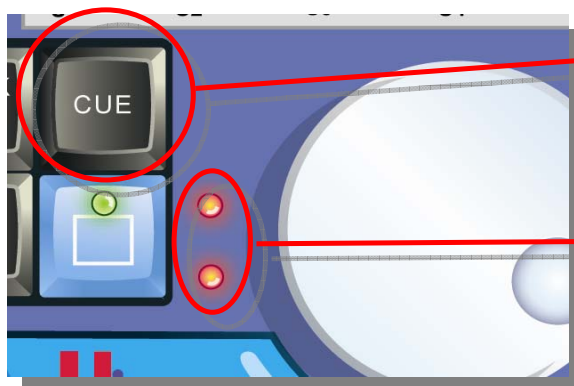

1 Press and hold the CUE key then press then release the wheel.

2 Turn the wheel to browse through the list of cue points. The jog/shuttle led flash.

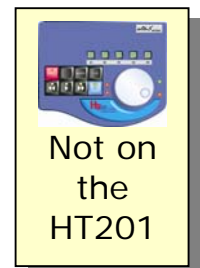

3 Operation

3 Press the CUE key to cue the VTR.

4 Press the wheel again to abort a cue recall.

Description of display

Timecode at current cue memory location (empty in this example).

Next cue memory location that will be used to store a cue

Duration of cue



What are the S keys? Current cue memory location

The S keys are shortcut keys to 5 cue memory locations. Any cue point can be stored to any of the S keys.

How to store cue points to the S keys



The timecode that was stored at the S key will be overwritten by the new timecode.

There two methods for storing cues to S keys.
Method 1 – storing a cue already created.



Not on the HT201

- 1 Recall the cue point by browsing the cue memory locations.

- 2 Press the desired S key to copy and store the timecode to this S key.

Method 2 – storing a new cue

- 1 Press and hold an S key then press the MARK IN key.

How to recall a cue point using the S keys

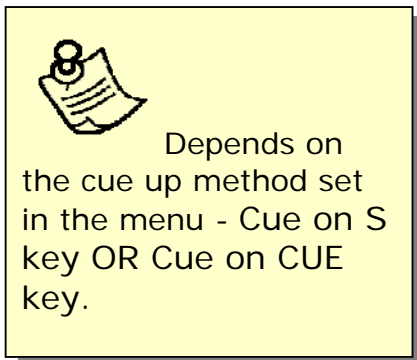

Pressing any S key on its own will recall and cue the VTR.

Advanced Operations

How to loop a cue

To Loop a cue, first make sure that the cue has a valid IN and OUT point. Cue to the desired IN point and then press and hold CUE then PLAY.

How to do an auto cue

During a live event it is sometimes desirable quickly come out of RECORD or PLAYBACK to cue back to a point of interest. With the auto cue mode turned ON

3 Operation

then turning the wheel will drop the VTR into jog, and cue it back by the number of frames set by the "auto cue delay" setting. The VTR is also switched from EE mode into PB mode.

How to clear a single CUE memory location

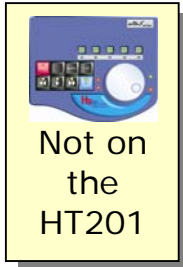

There may come a time when you wish to remove an individual CUE from its cue memory location.

- 1 Recall the cue point you wish to remove. Press Cue + Jog/Shuttle knob to enter Cue menu.
- 2 Press and hold the MARK IN button for more than 3 seconds.

How to clear the memory, and restore to factory default?

There are times when you may want to completely erase all the cue memory locations of the controller and return the menu settings to there factory defaults for example after a software upgrade.

- 1 Turn of the power.
- 2 Press and hold the STOP key.
- 3 Turn the power back on.
- 4 Release the STOP key.



How to change the timecode source

You change the timecode settings in the menu (see the menu section in this manual for entering the menu). The TC setting changes the time code source data (hours, minutes, seconds and frames) that is displayed on the time code display of the controller for the connected VTRs.

The selections are: CTL, LTC, VITC and AUTO. If the display shows [--:--:--:--] then no valid time code can be read.

CTL Tape running time (hours, minutes, seconds and frames) is computed from the recorded control (CTL) signal during playback, or a count of control signal pulses during recording. These counters do not usually keep a highly accurate track of tape position.

LTC or Longitudinal time code in either 24 hour or +/- 12-hour format is usually recorded on an audio track on the tape.

LTC is read by the internal time code reader during playback or longitudinal time code reader during recording.

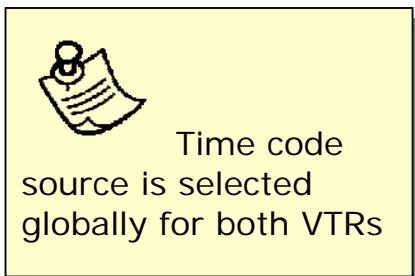

VITC - Vertical interval time code. This is recorded on an invisible area in the video track, and during playback read by the internal time code reader or vertical interval time code reader during recording.

3 Operation

AUTO Time code is selected automatically by the VTR depending on the speed of the tape. Typically VITC is selected when the tape transport speed is up to half speed and LTC when it is more than half speed.

Setting TCG and CTL



To set TCG the VTR must be set to TC generator pre-set mode.

Specific times for the VTR timecode generator and CTL counter may be set from within the menu.

It is also possible to recall the last time code or control track time set. For example to store and recall 09:58:00:00,

enter the menu select TCG and use the wheel to change the time to 09:58:00:00

How to enter and exit the altuS SETUP menu.

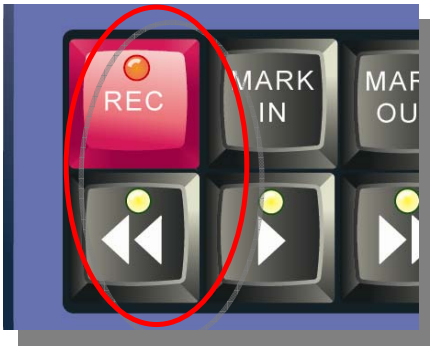

There are times when you may want to change certain altuS operational parameters. This is accomplished via its SETUP menu. It is here where you will be offered setup parameters to choose from. To enter and exit SETUP:

Press and hold the REC key and the REW key.

How to change operational parameters in the SETUP menu

Turn the WHEEL to “point” the display chevron to the line item you wish to change, a chevron > indicates the active display line.

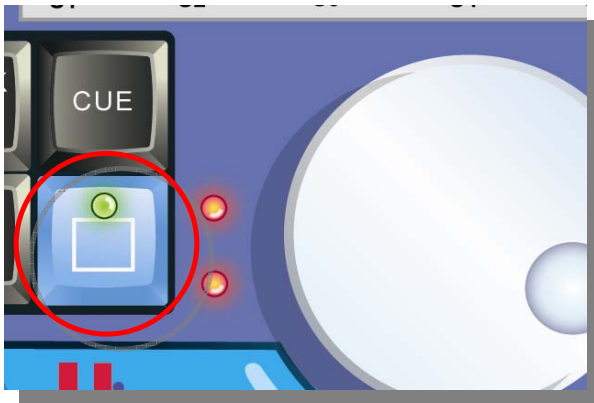

Press and hold down the STOP key to change the parameter of interest.

Change the parameter by turning the WHEEL.

Menu Operational settings

1. Eject

YES or NO

NO ^{DEF}

Description: Ejects tape from VTR.

When tape is ejected the MENU mode is exited, the bleeper will sound and a 'Cassette out' message will be displayed.

2. TC Mode

Cue controller only

CTL, LTC, VITC, AUTO **AUTO** ^{DEF}

Description: Set the timecode standard.

3. Set CTL

hh:mm:ss:ff

Description: Allows the tape timer numbers inside the VTR to be set. Some VTRs will not allow the tape timer to be set, so this item may have no effect. To move between hh:mm:ss:ff turn the wheel. Press and hold down the || key, and turn the wheel to alter the numbers.

To recall the last setting stored, enter the menu mode and select CTL, press the TC button to load the new CTL and exit the menu mode.

4. Set CTL mode

12Hr / 24Hr

24 ^{DEF}

Description: Changes the CTL display to display timecode in +/-12 hours mode or 24 hours mode.

5. Set TCG

hh:mm:ss:ff **00:00:00:00** ^{DEF}

Description: Allows VTR T/C generator numbers to be preset. Useful to force an edit or hard record to start with tape time code at a particular number. To move between hh:mm:ss:ff turn the wheel. Some VTRs do not support this command. Press and hold down the || key, and turn the wheel to alter numbers. To recall the last setting stored, enter the menu mode select TCG. Press the T/C button to load the new TCG and exit the menu mode.

6. Mark Preroll

nn secs **0 secs** ^{DEF}

Description: Offset the MARK IN time. The timecode stored will be the time at the point the MARK IN key was pressed less the mark preroll time

7. Cue up method

Cue on S key, Cue on CUE key **Cue on S key** ^{DEF}

Description: Effects the cueing of the connected VTRs.

Cue on S key Pressing an S key cues any stored cue immediately.

Cue on CUE key Pressing an S key displays stored cue, now have to press CUE.

8. Cue mode

Stop, Play **Stop** ^{DEF}

Description: Effects the cueing of the connected VTRs.

Stop Cues the VTR and goes into still.

Play Enters the play mode automatically once an operator has initiated the CUE command.

3 Operation

9. Stop at

Off, End, Out

Off ^{DEF}

Description: End, stores the T/C at the point the recorded channel was stopped (less 6 frames), when replayed in PLAY or VAR mode the controller will stop the VTR at this T/C before the playback overruns into unwanted black. Out stops the playback on the out point of a cue in playback mode.

10. Fast Cue

NO or Yes

NO ^{DEF}

Description: Some VTRs cue tape very slowly using the standard cue command. Fast cue mode allows fast forward and rewind commands in CUE mode. These commands are used for cueing until the tape position is within a few seconds of the cue point, and then the cue command is issued.

11. Mark Increment

IN, OUT

IN ^{DEF}

Description: Describes the action of the mark keys.

12. Rec Inhibit VTRx

NO or Yes

NO ^{DEF}

Description: Inhibits recording on selected channel.

13. Lock VTR

Cue controller only

NO or YES

NO ^{DEF}

Description: Locks the PLAY and RECORD transport controls only. Note: the controller must be in PLAY or RECORD first before turning this mode on. Enter menu again to turn OFF lock.

14. Auto Cue Delay

nn frms

5 frames^{DEF}

Description: Sets the amount of time the VTR will cue back after an auto cue.

15, 16 & 17 Jog Rate, Var Rate and Sht (Shuttle)Rate

Min, Slow, Norm, Fast, Max

Normal^{DEF}

Description: Changes the reaction time of the wheel input to the tape being replayed to compensate for tape, disk and operator preference. For example if the Jog speed is set to Min, then more than one complete turn of the wheel is required to advance a frame.

Setting	Jog reaction time	Shuttle range	Var range
Min	Minimum	+/- 1.0	+/- 0.25
Slow	Slow	+/- 2.0	+/- 0.33
Norm	Norm ^{DEF}	+/- 15 ^{DEF}	+/- 0.5
Fast	Fast	+/- 24	+/- 1.0 ^{DEF}
Max	Maximum	+/- 50	+/- 2.0

18. Clear Cues

NO, YES

Description: Clears all the cues from the memory of the controller.

19. Clear Config

NO, YES

Description: Restores the factory default conditions. See all items marked as^{DEF}.

3 Operation

20. Auto cue

Off, Wheel

Off^{DEF}

Description: Turning the wheel will drop the VTR into jog, regardless of the state, ie record, play, etc.

21. Bleeper

Off, On, Error

Off^{DEF}

Description: Turn the beeper function on/off.

22. Video Std

PAL, NTSC

PAL^{DEF}

Description: Sets the T/C to run on either PAL or NTSC standard

23. Duration Format

HH:MM / SS:FF

MM:SS^{DEF}

MM:SS

Description: Changes the format of the duration displayed on the screen.

24. EE mode auto or full

AUTO OFF/ON

AUTO - ON^{DEF}

FULL OFF/ON

Description: Change the EE function from automatic to manual.

4 Trouble Shooting

The following section lists commonly asked questions and their solution:

Why do labels appear as | | | | when powering the controller for the first time?

This indicates the default settings of the controller need to be stored in the non-volatile memory (see Chapter 3 – Engineering menu - Clear Config).

The controller has emitted several short 'beeps' and the remote LED has gone off. What's the problem?

Check that the VTR is not switched into local or that the RS422 communications link is not disconnected.

How do you change settings in the Menu?

The (**Stop**) key MUST be held down to allow the wheel to change assigned parameter values on the bottom display line.

Where is the tape eject button?

This is menu option 1.

There is no communications to or from the VTR?

Check that the cable adaptors have been made correctly.

Addendum

Summary of functions

Function	Keys	Description
Play	[▶]	The VTR will play
Still / Stop	[■]	First press the VTR will be in still mode, second press the VTR will be in stop mode.
Standby Off	[■] for > 1 second	The VTR will "spool down" – head drum will stop and tape unthread
Record	[REC] + [▶]	Puts the selected VTR into Record, press play and record together
Jog	● ● press wheel	Puts the selected VTR into jog mode
Shuttle	○ ● press wheel	Puts the selected VTR into shuttle mode
Vari Speed	● ● press and hold the wheel	Puts the selected VTR into variable mode the range depends on the menu setting
Loop Play	[CUE] + [PLAY]	Sets the current cue into loop playback mode.
Timecode mode	Menu setting	The timecode can be set to LTC, CTL, VITC and AUTO
Make a Mark In point	[MARK IN]	Creates a Cue in point.

Function	Keys	Description
Make a Mark Out point	[MARK OUT]	Creates a Cue out point. Cue No. displayed briefly, when button pressed
Browsed saved Cues	[CUE] + press wheel	This will allow all saved cues to be viewed. Scroll through using the jog/shuttle wheel. Press wheel to exit.
Group Channels	[1]+[2]	Hold down the channel buttons, they are grouped together
Go to a Cue	[CUE]	Will cue the controller to the entered cue point
Eject the tape	[MENU]	Eject must be selected from the menu using the jog wheel
Delete a CUE	[MARK IN] for > 3 seconds	Empties the current cue memory location.

Outline dimensions

The altuS has the following outline dimensions:

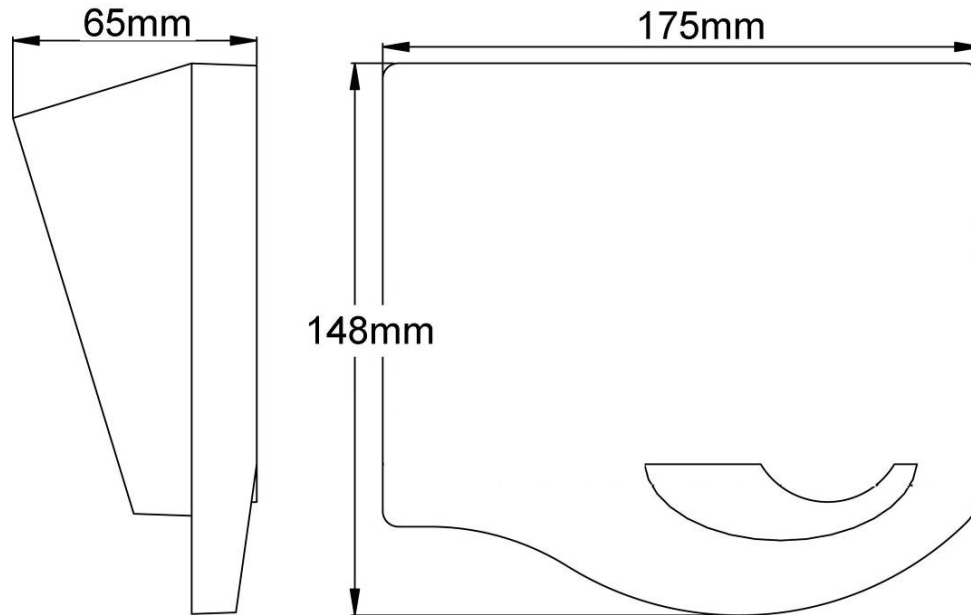

Software Updates

Download the software update wizard activ8 from the Hi Tech Systems support web site at:

http://www.hitechsys.co.uk/html/support/support_overview.html

and contact Hi Tech Systems for the latest software version.

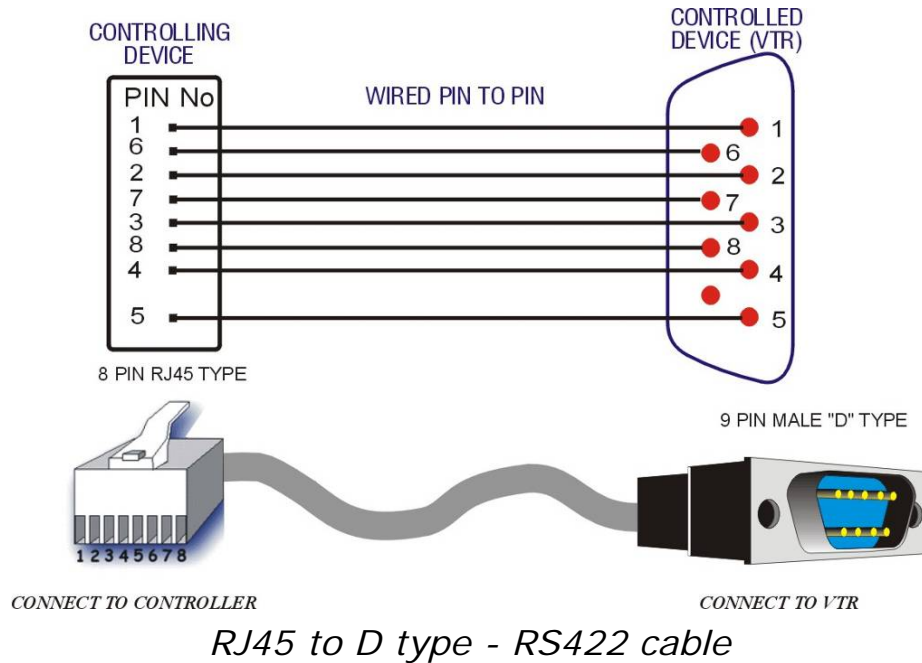

Cable pin out reference

The following diagrams are provided for those wishing to make their own cables.

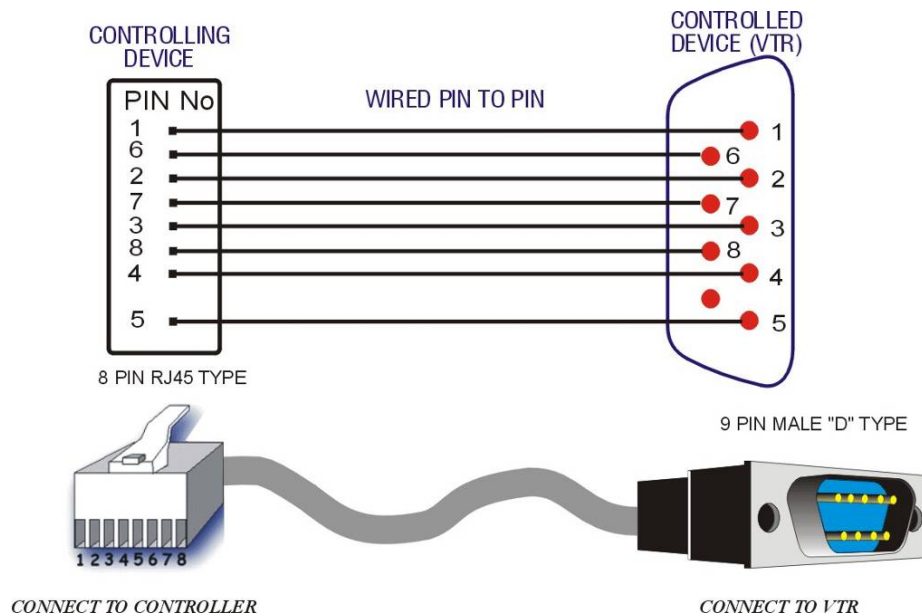

Addendum

RJ45 to D type - RS422 cable

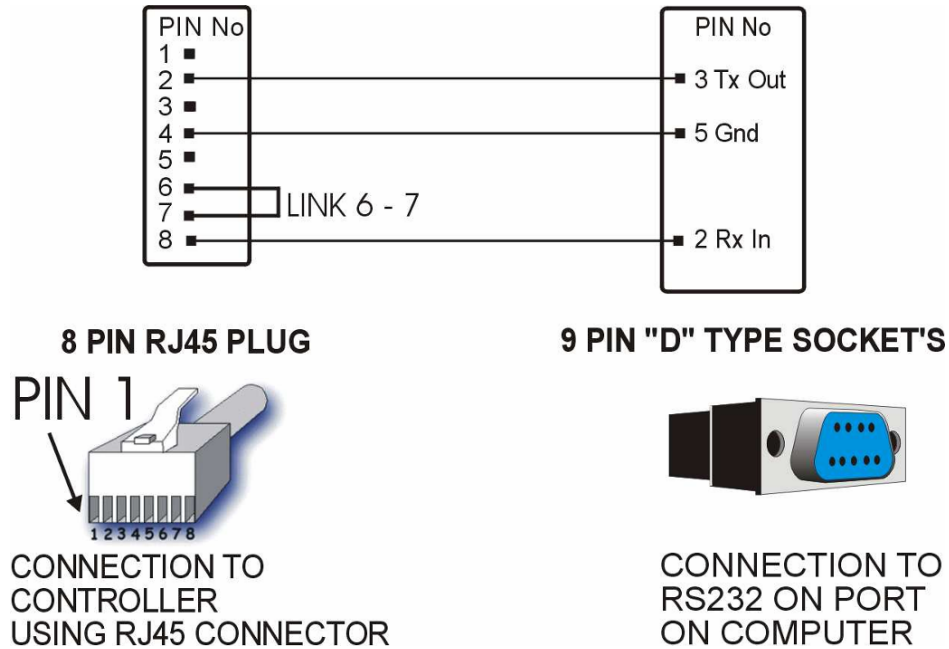

RJ45 to D type – RS232 cable

Making a software upgrade serial cable

Notes on PC serial connectors

Some computers, particularly laptops have odd earth arrangements on the RS232 connector, making the download problematic. If possible, use a desktop PC for performing s/w updates.

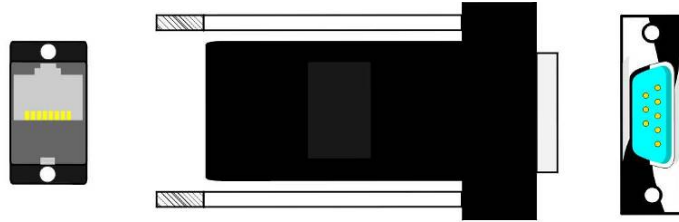

PIN	Description	Colour (shielded)	Colour (un-shielded)
1	Chassis Gnd	BLUE	BLACK
2	Rx A data	ORANGE	YELLOW
3	Tx B data	BLACK	ORANGE
4	Tx Gnd	RED	RED
5	N.C	GREEN	GREEN
6	Rx Gnd	YELLOW	BROWN
7	Rx B data	BROWN	GREY
8	Tx A data	WHITE	BLUE

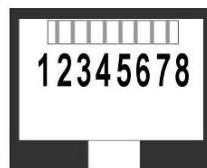

VIEW FROM THE OUTSIDE

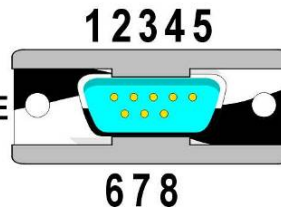

Making the RJ45 to RS422 *male* adapters

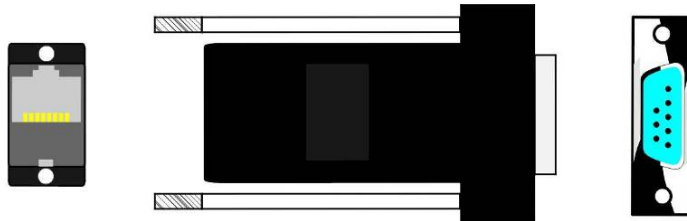

PIN	Description	Colour (shielded)	Colour (un-shielded)
1	Chassis Gnd	BLUE	BLACK
2	Rx A data	ORANGE	YELLOW
3	Tx B data	BLACK	ORANGE
4	Tx Gnd	RED	RED
5	N.C	GREEN	GREEN
6	Rx Gnd	YELLOW	BROWN
7	Rx B data	BROWN	GREY
8	Tx A data	WHITE	BLUE

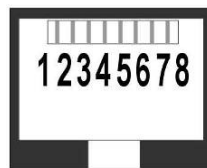

VIEW FROM THE OUTSIDE

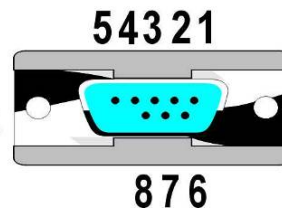

Making the RJ45 to RS422 *female* adapters

6 Specification

Control ports

Communication Format: RS-422-A

Communication Channel: Full Duplex

Data Signalling Rate: 38.4 Kb/s (K bits per second)

Communication Protocol: SONY 9 pin RS422

Serial connectors: 2 x RJ45 – 8 pin sockets

VTRs controlled: VTRs that support the Sony RS422 9 pin protocol

Power

Mains input: 110 – 240V AC IEC to Female XLR DC Mains Adaptor

Voltage: 12V DC

Power consumption: Less than 5 watts

General

Operating Temp: 0 - 35 Deg C