

HT884/8 VTR/DDR Controller
HT884c/8c Cue Controller
HT884s/8s Slo Mo Controller
Users Manual

HT800 Series VTR/DDR
Controller

Software version: 3.34c

Document file: HT800 manual Version 3.20



History

| Date | Description | Version |
|---------|--------------------------------|---------|
| Jan 08 | GPI functions added | 3.20 |
| Sept 07 | Update cueing functions | 3.10 |
| July 06 | New functions added | 3.00 |
| Feb 06 | Update manual with smart wheel | 2.3 |

Hi Tech Systems Ltd
Holbrook House
Oakley Lane
Oakley
Basingstoke
Hampshire RG23 7JY
Tel: +44 (0) 1256 780880
Fax: +44 (0) 1256 782600
Email: support@hitechsys.co.uk
Web: www.vtrcontrol.com
www.diskcontrol.com

The hardware/software and manual are copyright 1998 - 2008 by Hi Tech Systems Ltd. All rights reserved. The operating code is licensed by Hi Tech to the original purchaser only. It is not permitted to copy, sell or use this product in any other way than is intended.

All trademarks acknowledged.

According to the U.K. copyright law, unauthorised reproduction of software can be subject to civil damages.

The information in this document is subject to change without notice.

In no event will Hi Tech Systems Ltd be liable for direct, indirect, incidental or consequential damages resulting from any defect in the software even if they have been advised of such damages.

Contents

| | | |
|------------|---|-----------|
| 1 | INTRODUCTION | 1 |
| 2 | INSTALLATION | 4 |
| | Unpacking | 4 |
| | Desk mounting | 4 |
| | Warnings – read before installation or use | 5 |
| 2.1 | EXTERNAL CONNECTIONS | 6 |
| | Power requirements | 6 |
| | Connecting controlled devices | 8 |
| | Controller Configurations | 8 |
| | RJ45 connector pin out | 9 |
| | Installing the GPI I/O option | 10 |
| | GPI interface pinout | 10 |
| | Using GPIs | 11 |
| | Using the on-air tally | 12 |
| | Using additional controllers | 12 |
| 3 | OPERATION | 15 |
| 3.1 | USING THE MAIN CONTROLLER KEYS | 16 |
| | Device selection | 16 |
| | Selecting multiple devices | 17 |
| | Assigning an external controller | 17 |
| | Menu, PB and Timecode settings | 18 |
| | MENU | 18 |
| | PP/EE | 18 |
| | T/C | 18 |
| | Using CUEs | 19 |
| | Entering cues MARK IN/OUT Keys | 19 |
| | Cues functions on the HT884/8c | 20 |
| | Cues functions on the HT884/8s and HT884/8 | 21 |
| | Looping Cues | 21 |
| | Cue memory location table | 21 |
| | Deleting single cues | 22 |
| | Selecting timecode source data | 22 |
| | Setting TCG and CTL | 23 |
| 3.2 | EDITING | 24 |

| | | |
|---|---|-----------|
| Edit delay | 25 | |
| Start delay | 25 | |
| Marking in and out points | 25 | |
| Editing functions on the HT884/8c | 27 | |
| Editing functions on the HT884/8s and HT884/8 | 27 | |
| Making a single machine edit | 27 | |
| Making a two machine edit | 28 | |
| More than one recorder | 29 | |
| 3.3 | SLOW MOTION CONTROLLER-USING THE T-BAR | 30 |
| Keypad | 30 | |
| ESC key | 31 | |
| Var | 31 | |
| Still | 31 | |
| Goto TC | 31 | |
| Goto Cue No | 31 | |
| T-Bar shuttle key | 32 | |
| Pre-set variable key | 32 | |
| DDR mode (simultaneous play/record) | 32 | |
| Select disk mode | 32 | |
| Start Recording | 33 | |
| Live / Playback mode or EE routing | 33 | |
| Live Jog | 33 | |
| 3.4 | CUE CONTROLLER | 34 |
| Keypad | 34 | |
| ESC key | 35 | |
| Goto TC | 35 | |
| Goto Cue No | 35 | |
| DELETE | 35 | |
| 4 | USING THE MENU SYSTEM | 36 |
| Navigating the menu | 36 | |
| 5 | DOUBLE SHOOTING | 45 |
| 6 | ADDENDUM | 47 |
| 6.1 | SUMMARY OF FUNCTIONS | 47 |
| 6.2 | OUTLINE DIMENSIONS | 47 |
| 6.3 | DISASSEMBLY | 47 |
| Removing the main PCB | 47 | |
| Replacing the PCB | 47 | |

| | |
|-------------------------------|-----------|
| Software Updates | 47 |
| 6.4 CABLE PIN OUT REFERENCE | 47 |
| Notes on PC serial connectors | 47 |
| 7 SPECIFICATION | 47 |

1 Introduction

The Hi Tech HT800 series of VTR and DDR controllers provide a user-friendly remote control interface for professional and broadcast videotape and disk recorders.

The controllers now utilise a control wheel, called “**smart**  **wheel**” that is our first implementation of Haptic technology – “Haptic” is Greek for the science of touch. Our controller can be programmed to give the operator different tactile and kinesthetic sensations depending on the mode of operation, such as jog, indented incremental shuttle speeds and so on.

There are three basic models, a standard desktop model with a crafted shuttle/jog control, an enhanced model which adds a direct entry keypad and a deluxe Slo-Motion Controller that adds a key pad and a T-Bar control arm.

HT800 series VTR and DDR Controllers



HT884/8



HT884/8c



HT884/8s

Introduction

All of the three models are available as four-machine and eight-machine versions.

This manual covers the following models:

| | |
|-----------|---|
| HT884/8 | 4 and 8 Machine VTR and DDR Remote Controller |
| HT884s/8s | 4 and 8 Machine Slo-Motion Controller with key pad for direct entry of T/C data and T-Bar |
| HT884c/8c | See the separate HT800c getting started guide for a description of the cueing functions |

Main features

- Controls all devices conforming to the Sony RS422 'P2' protocol
- Custom jog/shuttle wheel utilising control that is our first implementation of "Haptic" technology.
- High visibility vacuum fluorescent display
- On-Air indicator
- Optional direct entry key-pad and Slo-Mo T-Bar
- Optional GPI interface with 4 programmable trigger inputs and outputs
- Set tape timer, timecode generator and timecode display
- Dedicated timecode select of VITC, LTC, CTL and Auto plus EE/PB switching
- Multiple cues with Mark-In and Out points
- 2 machine insert and assemble editing
- Gang control of any combination of VTRs
- Programmable cueing modes (cue to still, cue and play)

Main features continued

- Programmable device labels
- Selectable RS422 'loop through' connector
- Variable jog and shuttle sensitivity for different VTRs/DDRs
- Controls any DDR supporting Sony VTR emulation
- Internal bleeper to alert warnings (off line, cassette out etc)

Accessories supplied:

- 4 or 8 RJ45 to 9 pin 'D' type adaptors (HT8821/m)
- User's manual (this manual) on CD

Available options:

- Spare RJ45 to 9 pin 'D' type adaptor male for direct connection to VTR
- Spare RJ45 to 9 pin 'D' type adaptor female for connection to end of "standard" RS422 cable
- GPI interface: 4 GPI inputs/GPI outputs
- Technical manual
- Flight case for HT800s series

Note: In this manual HT800 Series VTR and DDR controllers are referred to as 'controller'. VTR, laser and disk recorders are referred to as 'VTR'.

2 Installation

The Hi Tech Series of VTR and DDR Controllers are designed as desk-top units.

Unpacking

The Hi Tech Systems HT800 Series of VTR and DDR controllers are shipped in a carton, which may contain other optional items within the packing, and care should be taken to ensure that these are not thrown away. The contents of the carton are as indicated on the delivery note. Carefully unpack and check for shipping damage and shortages. Report without delay, any damage or shortages to Hi Tech Systems Ltd.

Desk mounting

The HT800 series of desk mounting controllers require no special fixings, but can be mounted into a desk as a 'drop through' unit.

Outline dimensions for all models are given in the Addendum at the back of this manual.

Warnings – read before installation or use

Do not apply AC mains power until all the preliminary activities and interconnections have been completed.

AC voltages in excess of 100 volts can be dangerous and even lethal under certain conditions. To prevent injury to personnel and damage to the controller, ensure that it is disconnected from the AC power source (not just switched off) before any dismantling takes place.

Only suitably qualified engineers should carry out maintenance.

Ensure that the power earth connection is correctly made.

Always check that the supply voltage specified is correct for the local AC power supply voltage.

The controller consists of electronic parts. Do not drop the controller or bump it against other objects or place the controller near heat sources such as radiators or air conditioning ducts.

Care should be taken so that solid objects or liquid do not fall into the Controller enclosure.

Clean the case with a soft dry lint free cloth, or a soft cloth lightly moistened with a mild detergent solution. Do not use any type of solvent such as alcohol, which might damage the special 'Nextel' finish.

Installation

2.1 External connections

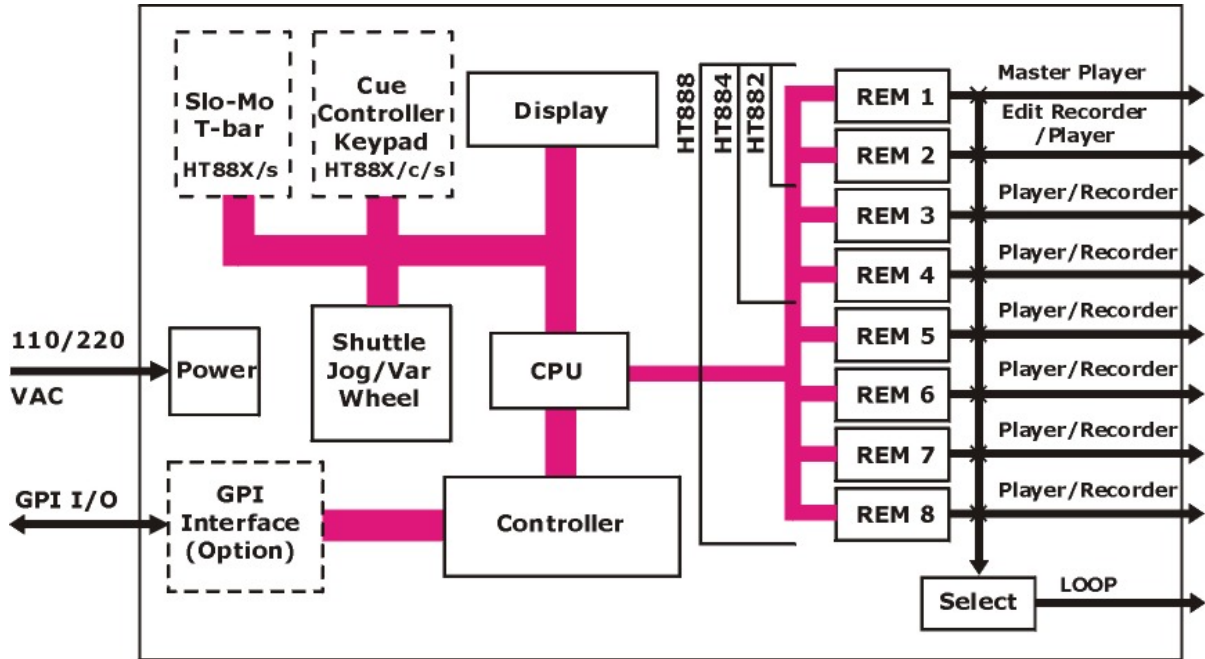

HT800 series VTR and DDR Controller



HT888 rear view – with Link board option

Power requirements

In the UK, the mains plug should be approved to BS1363 and be fitted with a 3 amp fuse approved to BS1362.

All accessible metalwork in the room and the safety earth connections of other electrical circuits must be electrically connected together in accordance with safety regulations BS6204. This can be accomplished either by separate routes to the building earth or by bonding together or a combination of the two.

A suitable double-pole earth leakage protection device, conforming to BS6204, VDE0805 and IEC435 must be used to protect power supplied to the unit.

Note: Check the mains input connector voltage setting. To change the voltage, reverse the fuse holder. Connect a power lead to the mains input when ready.

Connecting controlled devices

Controller Configurations

| Function | Connections |
|--|--|
| Normal VTR/DDR control | Any remote connection can be used |
| Editing (Insert or Assemble mode) | In two-machine editing the first RS422 port, REM 1 is reserved as master play device port and REM 2 is reserved as a recorder port. |
| Dubbing (Insert or Assemble mode) | If used in dub mode, REM 1 is reserved for master play machine, but record dub machines may be connected to any of the remaining ports (REM 2 to REM 8, depending on version). |
| Slow Motion controller for DDR control (Disk mode On) | 4 port version – play channels to Rem 3 and 4, record channels to Rem 1 and 2 8 port version – play channels to Rem 5,6,7 and 8; record channels to Rem 1,2,3 and 4 |

Note: SEE SEPARATE NOTES ON SPECIFIC DDR CONFIGURATIONS.

The RS422 device control ports are implemented as RJ45 connectors to make the best use of space at the rear of a desk-top unit.

To convert RS422 ports on VTRs and other controlled devices to use RJ45 patch cables use the supplied HT8821/M converter at the VTRs.

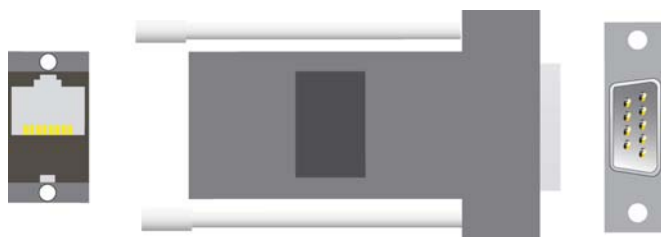

HT8821/M converts VTR serial ports to RJ45

Note: It is recommended not to exceed 100 metres of CAT 5 cable.

RJ45 connector pin out

| Pin No | Description | RJ45 Connector |
|--------|-------------|--|
| 1 | Chassis Gnd | <p>Chassis Connector</p> <p>Cable Connector</p> <p>View from front</p> |
| 2 | Rx A data | |
| 3 | Tx B data | |
| 4 | Tx Gnd | |
| 5 | N.C | |
| 6 | Rx Gnd | |
| 7 | Rx B data | |
| 8 | Tx A data | |

CAT 5 VTR/DDR remote cables are connected to the RJ45 sockets labelled REM 1 and REM 2 (plus REM 3 and 4 for 4 machine controllers and REM 5 to 8 for 8 machine controllers).

If used in dub mode, REM 1 is reserved for master play machine, but record dub machines may be connected to any of the remaining ports (REM 2 to REM 8, depending on version).

Installation

Installing the GPI I/O option

The HT8823 GPI interface option provides 4 GPI inputs and 4 GPI outputs. To install the GPI interface proceed as follows:

- Remove the power cord
- Remove base chassis – 4 screws each corner
- Remove the rear option-slot cover
- Fit the GPI interface into the vacant option-slot and refit base chassis
- Insert the power cord

GPI interface pinout

| Pin No | Description | 25 way female 'D' connector |
|-----------|-------------|-----------------------------|
| 13, 25 | Chassis Gnd | |
| 11, 23 | 12V out | |
| 10, 22 | 12V in | |
| 14 | GPI - A | |
| 15 | GPI - B | |
| 16 | GPI - C | |
| 17 | GPI - D | |
| 5 - 9, 12 | Not Used | |
| 1 | Trigger - A | |
| 2 | Trigger - B | |
| 3 | Trigger - C | |
| 4 | Trigger - D | |
| 18 - 21 | Not Used | |

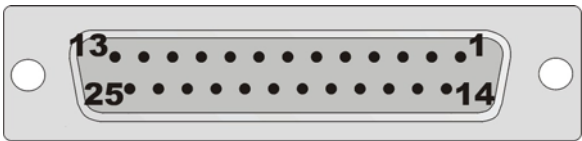

View from front

The following table shows the electrical characteristics of the GPI Outputs and Triggers (Inputs).

| GPI | Description |
|------------------------------------|--|
| A, B, C, D OUT | <p>Normal output state when there is no trigger output set is logic high (5V).</p> <p>A logic low is output when the programmed trigger has been set.</p> <p>A maximum current of 200mA can be taken from each of these GPI's.</p> |
| A, B, C, D IN (Trigger) | <p>Make these connections to the ground connection (pins 1, 14) to control the programmed Triggers that have been set.</p> |

Using GPIs

| GPI name | GPI IN | GPI OUT |
|-------------|--------|-------------|
| None | x | x |
| Stop | ✓ | ✓ |
| Play | ✓ | ✓ |
| Rewind | ✓ | ✓ |
| Fast Fwd | ✓ | ✓ |
| Cue In | ✓ | ✓ always on |
| Mark In | ✓ | ✓ |
| Mark Out | ✓ | ✓ |
| VTR | x | ✓ |
| Out-5s | x | ✓ (pulse) |
| Out-0s | x | ✓ (pulse) |
| Tally (LED) | ✓ | x |

Installation

CUE In - cues the VTR to the last entered cue location.

VTR - outputs a trigger when a different VTR is selected.

Out-5s – outputs a trigger pulse 5 seconds before the mark out point.

Out-0s – outputs a trigger pulse at the mark out point.

GPIs are independent and can be set specifically to any VTR. Select the VTR first before assigning the GPI function, the selected VTR then has that GPI or GPIs assigned to it. The menu will display all trigger settings but there is no indication as to which trigger is assigned to which VTR.

Using the on-air tally

The red on-air tally light on the controller is set from Trig A. Please refer to the Trig A, B, C, D Engineering Menu command in Chapter 4 for further details.

Using additional controllers

The LOOP RJ45 socket can be used to connect an additional remote controller or automation system, which may be assigned using the HT controller to any VTR or device emulating a VTR.

The HT8821/M adapter can be supplied for this purpose.

Note: Adapter pin out wiring can be found in the addendum at the end of this manual.

Installation

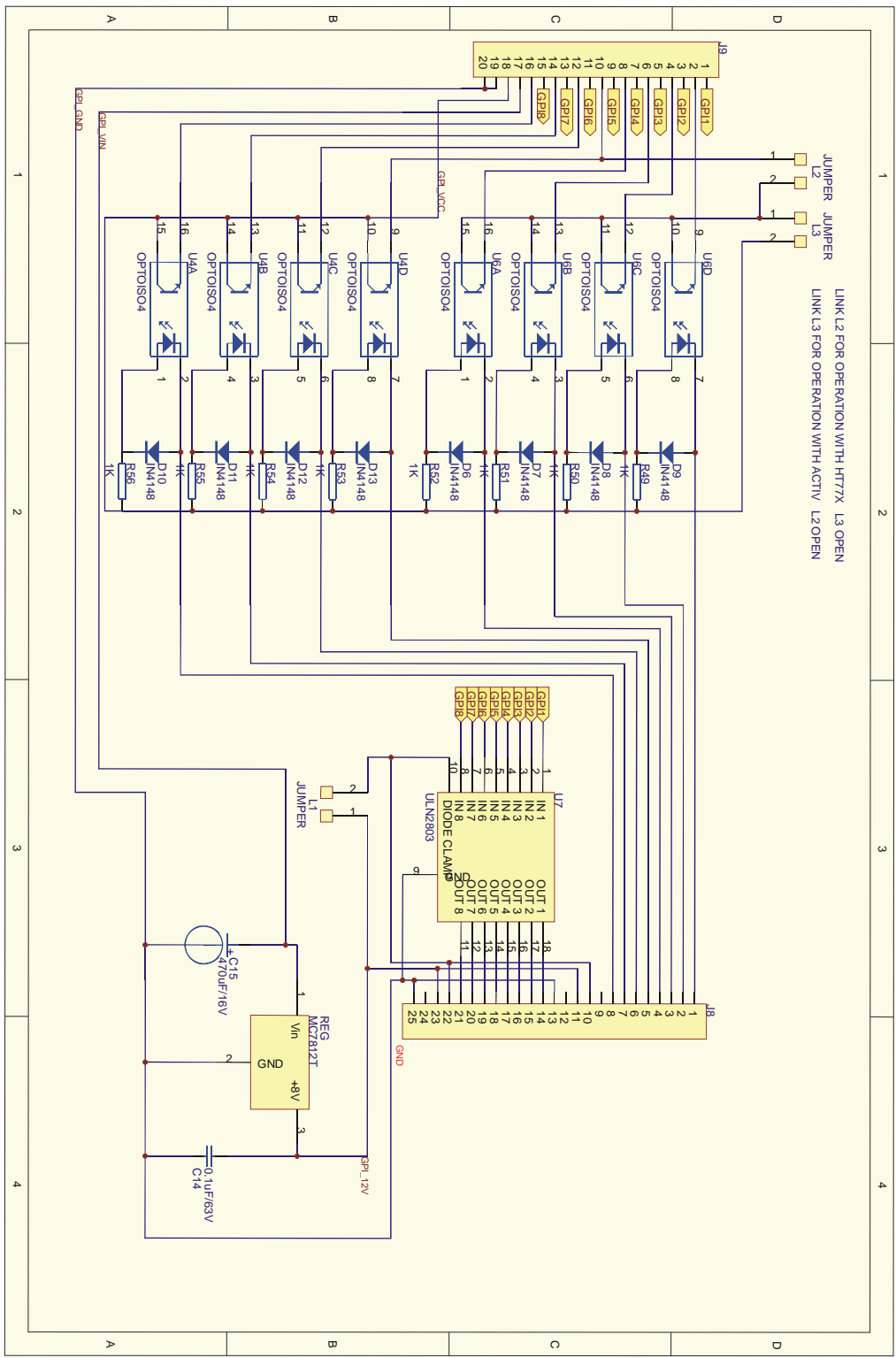

GPI Interface circuit layout

Note: As supplied LINK L1 is un-made.

3 Operation

The HT800 series VTR and DDR controllers' transport controls may be similar to the front panel controls of the VTR or device they are controlling but benefit from additional functionality.



The HT884 four machine controller

3.1 Using the main controller keys

Device selection



Port select LEDs are shared between upper and lower device select buttons

Port selection keys

To select a device for local control, press the desired numbered port selection key. A port select LED will illuminate and the display will be updated with the label, timecode and transport status appropriate for the attached device.

The selected device **MUST** be enabled for remote control. If the device is set to operate locally from its own control panel then the controller will not function and the select LED will not light.

Once the controller has control of the device, the REMOTE LED will illuminate. If the device is switched into local, or the RS422 communications becomes disconnected, the controller will sound several short warning 'bleeps' and the REMOTE LED will go off.

Selecting multiple devices

To select more than one device for multiple control, press and hold the shift key while selecting the devices with the numbered channel selection keys. Selected devices are indicated by illuminated LEDs.

Note: The device selected first is treated as the Master and its status (eg PLAY, STOP etc) is shown in the display. If a different channel is then selected it now becomes the Master. The Master channel has i

Assigning an external controller

To assign an external controller or automation system connected to the LOOP port to a control channel, press and hold the desired channel selection key for more than 2 seconds. The VTR status changes to show LOOP while the time code status changes to -
-:--:--:--.

The HT800 Series VTR and DDR controllers do not monitor or control the connected VTR and all commands to and from the connected controller to the VTR are transparent.

Note: It is not possible to control any other connected VTR in LOOP mode.

To take control back to the local controller press the channel selection key again.

Menu, PB and Timecode settings



MENU

Enters the menu settings (see section 4 for a description of the settings)

PP/EE

To receive video and audio signals from the tape during fast forward, rewind, still and standby press the PP/E-E key (below menu display) to select playback – the LED will be off. Pressing this key again will illuminate the LED and put the VTR into PB/EE mode where no video and audio signals from the input of the VTR will be received. To use auto EE routing, select auto EE in the menu.

T/C

Changes the timecode that the controller will read from the VTR. On the HT884/8c Cue controller this

button changes the display to show the timecode setting (it is set in the menu for the cue controller).

Using CUEs

CUE locations are timecode reference points that have been stored in one or more of the controller's 249 cue memory locations. Once a cue is stored a device can be made to search very quickly to a selected CUE point.

Note: Cue Functions are available on all the channels in Crash record mode or channel 1 in the editing modes.

Each cue location is stored as an In point and / or Out point. VTRs may be cued to any location. Cues are stored and recalled using the MARK IN/MARK OUT Keys, SHIFT and CUE, +/- keys.

For successful VTR cue operations the following conditions must be met:

- Continuous time code or tape timer information from tape.
- T/C key must be set for the same time code as on the VTR.

Entering cues MARK IN/OUT Keys

A CUE IN point can be entered 'on the fly' whilst the tape is moving by pressing the MARK IN key, and a CUE OUT point can be similarly entered by pressing the MARK OUT key. These actions are confirmed by the LED's under the corresponding button.

Operation

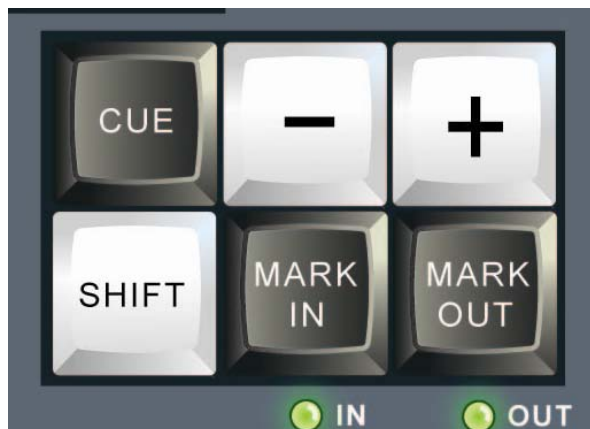

Mark IN and Mark OUT buttons are indicated with IN and OUT tally LEDs

Cue and Mark controls

An audible 'bleep' (the beeper has to be turned ON in the menu) and tally LEDs confirm that the point has been saved, and the saved time code number is briefly shown on the display.

If a dedicated direct entry keypad is available (HT800 series s or c models only), the timecode information can be entered using the keypad.

Cues functions on the HT884/8c

| | |
|---------------|-----------------------|
| [-] | decrement cue counter |
| [+] | increment cue counter |
| CUE | goto IN |
| [SHIFT]+[-] | goto IN |
| [SHIFT]+[+] | goto Out |
| [SHIFT]+[CUE] | browse cues |

Cues functions on the HT884/8s and HT884/8

| | |
|-------------|--------------------|
| [-] | cue previous |
| [-] | cue next |
| CUE | Cue last mark |
| [SHIFT]+[-] | set next cue point |
| [SHIFT]+[+] | set next cue point |

Looping Cues

To Loop a cue, first make sure that the cue has a valid IN and OUT point. Cue to the desired IN point and then press SHIFT and PLAY together. (With the S controller a slow motion loop can be performed by pressing SHIFT and VAR, this will take the speed of the T-bar) .

Cue memory location table

The following table shows how cues are stored after the MARK IN and MARK OUT keys are pressed for four different VTRs selected individually:

| CUE | VTR 1 T/C | VTR 2 T/C | VTR 3 T/C | VTR 4 T/C |
|---------|----------------------------|----------------------------|----------------------------|----------------------------|
| 1 | 10:12:30:00 10:14:30:00 | | | |
| 2 | | | 08:10:30:00 08:12:30:00 | |
| 3 | | 14:12:30:00 14:14:30:00 | | |
| 4 | | | | 00:10:30:00 00:12:30:00 |
| 5 - 249 | -- : -- : -- : -- | -- : -- : -- : -- | -- : -- : -- : -- | -- : -- : -- : -- |

Operation

Only the IN and OUT timecode data is stored. CUE information does NOT include the device port active when the CUE was created. Empty locations are displayed as [--:--:--:--]. When the capacity of locations is reached the message 'End of cues' is displayed.

Tip: Empty locations can be used to group locations according to use.

Deleting single cues

To delete any time code stored at any particular cue location, press the Shift and CUE keys. Turn the wheel to scroll through the locations. At the desired location, press and hold the Mark IN key for more than 1 second.

Selecting timecode source data

The TC button selects the time code source data (hours, minutes, seconds and frames) that is displayed on the time code display of the controller for all connected devices.

This is selected in the following sequence: CTL, LTC, VITC and AUTO by repeatedly pressing the TC key. If the display shows [--:--:--:--] then no valid time code can be read.

Note: Time code source is selected globally for all VTRs.

CTL Tape running time (hours, minutes, seconds and frames) is computed from the recorded control (CTL)

signal during playback, or a count of control signal pulses during recording. These counters do not usually keep a highly accurate track of tape position.

LTC or Longitudinal time code in either 24 hour or +/- 12-hour format is usually recorded on an audio track on the tape.

LTC is read by the internal time code reader during playback or longitudinal time code reader during recording.

VITC Vertical interval time code. This is recorded on an invisible area in the video track, and during playback read by the internal time code reader or vertical interval time code reader during recording.

AUTO Time code is selected automatically by the VTR depending on the speed of the tape. Typically VITC is selected when the tape transport speed is up to half speed, and LTC when it is more than half speed.

Setting TCG and CTL

Specific times for the VTR timecode generator and CTL counter may be set from within the menu.

It is also possible to recall the last time code or control track time set. For example to store and recall 09:58:00:00, enter the menu select TCG and use the wheel to change the time to 09:58:00:00.

Note: To set TCG the VTR must be set to TC generator pre-set mode.

3.2 Editing

The HT800 Series supports single and two machine editing for video, up to four analogue and up to eight digital audio tracks.

All record and playback devices must be correctly wired for video, audio, and time code.

Set the controller for either assembly editing or insert editing (see Chapter 4).

The assemble or insert lights will illuminate on the front of the VTR indicating that the VTR is set to edit.

The following 'rules' apply to all editing modes:

- IN point times must be less than OUT point times
- The controller does IN only edits by setting the OUT point time code to be the same as the IN point time code
- A suitable pre roll time should be set (normally 5 seconds - see Chapter 4)
- VTR1 is always regarded as the player and VTR2 (or more) is always regarded as the recorder
- The controller monitors all the VTRs whilst cueing to make sure that they have reached their IN points before an edit commences
- Synchronisation between VTRs during the edit is carried out by the VTRs themselves and is locked to the reference input of the VTRs
- The VTR remains in EDIT mode until it is turned off via the menu (see Chapter 4)

Edit modes also require the following switches to be set:

- Set the TC on the controller to read the same time code as on the VTR, e.g. AUTO
- Set the TC generator on the record VTR for REGEN (not PRESET) and INT (not EXT)

Note: The PLAYER cannot be put into record accidentally.

Edit delay

Corrects the delay time from sending the RECORD command to the VTR until recording starts.

If the recording starts late increase the delay. If the recording starts early decrease the delay, (pre-set to 5 frames - see Chapter 4 to adjust). The edit delay is global for all VTRs.

Start delay

Corrects any delay in the Player VTR going into playback, (pre-set to 0 frames - see Chapter 4 to adjust).

Marking in and out points

To start editing, it is required to set three edit points out of four points. The remaining edit point is automatically determined when the other three points have been set. Select the PLAYER by pressing the VTR selection key.

Operation

1. Search for the edit points using the jog or shuttle mode. At the desired points press the Mark IN key and Mark OUT key (IN only for an open ended edit). Then select the RECORDER by pressing the VTR selection key
2. Search for the edit IN point and press the MARK IN key. To see the values of the IN and OUT timecode points, select the PLAYER or RECORDER and press the + or - keys. The timecode is displayed.
3. Alternatively edit cue points can be entered directly using the numeric keypad, press the GOTO TC button.

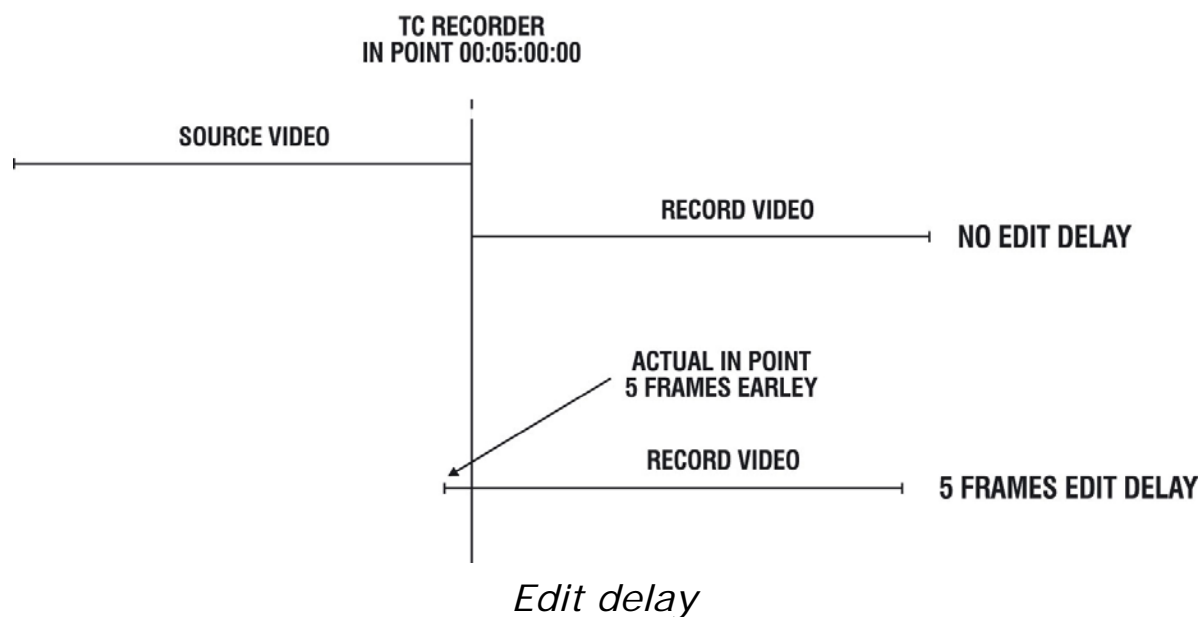

Editing functions on the HT884/8c

| | |
|-------------|-------------------------------|
| [-] | display IN time |
| [+] | display OUT time |
| [-]+[+] | display EDIT DURATION |
| CUE | goto IN point (ready to edit) |
| [SHIFT]+[-] | goto IN |
| [SHIFT]+[+] | goto OUT |
| REC | does the edit |
| REC+PLAY | preview the edit |

Editing functions on the HT884/8s and HT884/8

| | |
|-------------|-------------------------------|
| [-] | display IN time |
| [+] | display OUT time |
| [-]+[+] | display EDIT DURATION |
| CUE | goto IN point (ready to edit) |
| [SHIFT]+[-] | no function |
| [SHIFT]+[+] | no function |
| REC | preview the edit |
| REC+PLAY | does the edit |

Note: If both RECORDER and PLAYER are selected then both VTRs will cue to the recorder's IN or OUT points. RECORDER cannot be selected if PLAYER is selected first.

Making a single machine edit

To perform a recorder - only edit: select the RECORDER (by pressing the VTR selection key 2) and press the RECORD + PLAY keys. (RECORD on the HT884/8c).

Operation

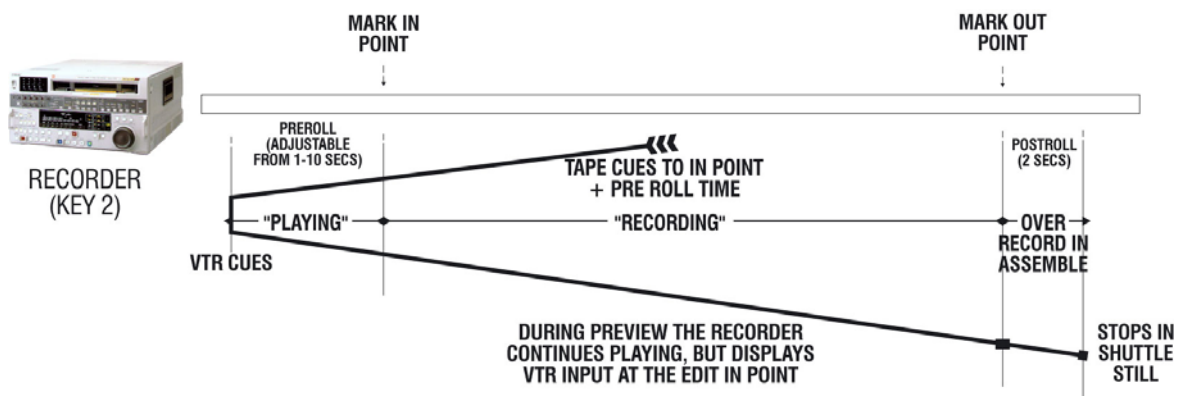

Single Machine Edit

Making a two machine edit

To perform a two machine edit: select the RECORDER then SHIFT + PLAYER to group the 2 VTRs and press the RECORD + PLAY keys. (RECORD on the HT884/8c).

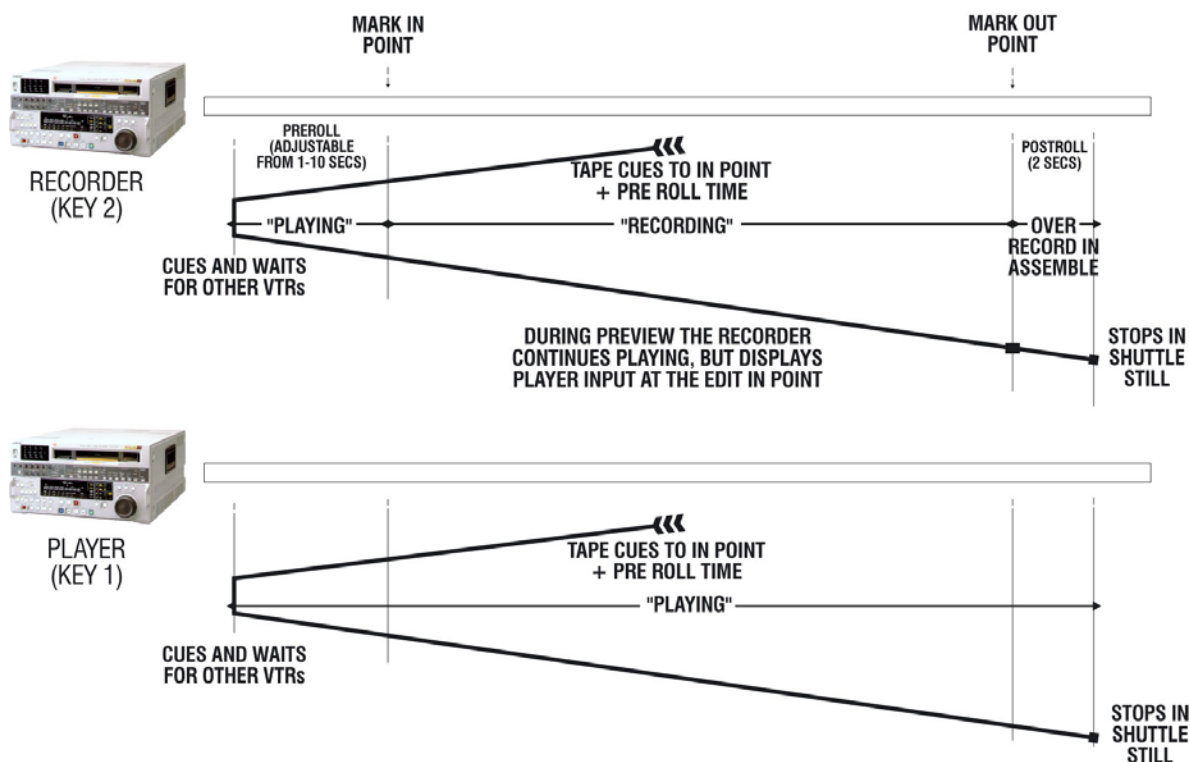

Two Machine Edit

Note: The RECORDER cannot be selected if PLAYER is selected first.

More than one recorder

If more than one recording is required (e.g. for duplication) then, after the master recorder has been selected, press and hold the Shift key while selecting the other desired VTRs (the selected VTRs are indicated by the illuminated LEDs).

3.3 Slow Motion Controller-Using the T-Bar

Slow motion controller 's' versions are fitted with a Penny & Giles T-Bar, numeric keypad, variable selection keys and special function keys.



Keypad for 's' version

Keypad

The numeric keypad allows a time code number to be entered directly for entering edit points and cueing and marking purposes. As numbers are entered they are formatted and displayed as hh:mm:ss:ff on the display.

ESC key

Press this key to abort information entered from the keypad before 'CUE' is pressed.

Var

This is a duplicate of the main VAR function. Press this key to assign 100% (Fast) to the T-Bar.

Still

This is a duplicate of the main Still function. Press this key to stop the transport.

Goto TC

Press this key to make the VTR locate to the timecode entered using the keypad.

Pressing ESC at any time cancels the operation. Normal VTR operation is available while this button is on.

Goto Cue No

Press this key to set the keypad to accept cue numbers instead of T/C numbers. Any number entered into the keypad is accepted as a cue location and is shown on the display as it is entered. Pressing the CUE key cues the VTR to the location entered.

Pressing ESC at any time cancels the operation. Normal VTR operation is available while this button is on.

Operation

T-Bar shuttle key

Press this key to turn the T-Bar into a shuttle control and set the VTR into shuttle. The shuttle range is: +/- 0, 0.05, 0.1, 0.2, 0.4, 1.0, 2.0, 4.0 with a 'dead' position in the centre of the T-Bar. This is useful for locating the exact start of the playback without having to use the jog/shuttle wheel.

Pre-set variable key

Press this key to select variable playback mode, controlled from the T-Bar, but using the variable range as set up in the menu (see Chapter 4).

The speed ranges available are:

| Min (%) | Slow (%) | Norm | Fast (%) | Max (%) |
|---------|----------|---------|----------|-------------|
| 0 to 25 | 0 to 33 | 0 to 50 | 0 to 100 | -100 to 200 |

DDR mode (simultaneous play/record)

Select disk mode

This mode of operation will be the most used and is ideal for instant slow motion replays. Select Disk On from the menu. In this mode the DDR recorder and player are controlled together. The record ports are ganged together (un-gang a channel by pressing SHIFT + that record channel, or change the menu setting to auto group off) and the playback channels are ganged together (un-gang a channel by pressing SHIFT + that playback channel).

Start Recording

To set the record channels recording press REC+PLAY. To stop the recording press STOP (if the record channels are in Record Lock press and hold the REC+PLAY for 2 seconds).

Live / Playback mode or EE routing

With any playback port selected, pressing the red record button will route the input to the output "LIVE" mode. It will then be possible to mark a cue while viewing the input and search to cue for instant replay.

Live Jog

This mode forces the disk to cue up from "Live" mode when the jog/shuttle wheel is moved. This way of operation is very popular and quick. The "Auto cue" menu setting must be set to "Wheel, T-bar or Both" for this to work. Increase the edit delay if cueing isn't reliable – this time determines how far back the DDR is cued.

3.4 Cue Controller

Cue motion controller 'c' versions are fitted with a numeric keypad, and special function keys.



Keypad for 'c' version

Keypad

The numeric keypad allows a time code number to be entered directly for entering edit points and cueing and marking purposes. As numbers are entered they are formatted and displayed as hh:mm:ss:ff on the display.

ESC key

Press this key to abort information entered from the keypad before 'CUE' is pressed.

Goto TC

Press this key to make the VTR locate to the timecode entered using the keypad.

Pressing ESC at any time cancels the operation. Normal VTR operation is available while this button is on.

Goto Cue No

Press this key to set the keypad to accept cue numbers instead of T/C numbers. Any number entered into the keypad is accepted as a cue location and is shown on the display as it is entered. Pressing the CUE key cues the VTR to the location entered.

Pressing ESC at any time cancels the operation. Normal VTR operation is available while this button is on.

DELETE

Deletes the current cue.

4 Using the Menu system

Press the menu key to access the menu functions.

Navigating the menu

Move forward and back through the menus using the wheel. A chevron > indicates the active display line.



*Hold down
|| key to
select
value*

HT800 Series Menu Display

To change the value assigned to a function press and hold down the || key, and turn the wheel.

While in the menu mode all other keys and functions are disabled except the 5 main transport functions (PLAY, RECORD, STOP, FFWD and REW) and the bleeper warnings.

Press the MENU key to exit menus.

Eject

YES or NO NO ^{DEF}

Description: Ejects tape from VTR.
 When tape is ejected the MENU mode is exited, the bleeper will sound and a 'Cassette out' message will be displayed.

TC Mode Cue controller only

CTL, LTC, VITC, AUTO CTL ^{DEF}

Description: Set the timecode standard.

Set CTL

hh:mm:ss:ff

Description: Allows the tape timer numbers inside the VTR to be set. Some VTRs will not allow the tape timer to be set, so this item may have no effect. To move between hh:mm:ss:ff turn the wheel. Press and hold down the || key, and turn the wheel to alter the numbers.

To recall the last setting stored, enter the menu mode and select CTL, press the TC button to load the new CTL and exit the menu mode.

Set CTL mode

12Hr / 24Hr 24 ^{DEF}

Description: Changes the CTL display to display timecode in +/-12 hours mode or 24 hours mode.

Set TCG

hh:mm:ss:ff 00:00:00:00 ^{DEF}

Description: Allows VTR T/C generator numbers to be preset. Useful to force an edit or hard record to start with tape time code at a

Using the Menu system

particular number. To move between hh:mm:ss:ff turn the wheel. Some VTRs do not support this command. Press and hold down the || key, and turn the wheel to alter numbers. To recall the last setting stored, enter the menu mode select TCG. Press the T/C button to load the new TCG and exit the menu mode.

Preroll

nn secs

5 secs^{DEF}

Description: Selects the VTR run-up time in seconds required to attain the correct speed at the Mark IN point. The correct value is required to make a stable edit.

The chosen value effects the Cue pre and post roll function.

Mark Preroll

nn secs

0 secs^{DEF}

Description: Offset the MARK IN time. The timecode stored will be the time at the point the MARK IN key was pressed less the mark preroll time

Rec mode

Crash, Assemble, Insert and Inhibit^{DEF}

Description: Affects the recording mode when RECORD and PLAY keys are simultaneously pressed.

Crash This is the fastest way to put a VTR into record. All video, audio tracks, linear timecode and control track are recorded and no attempt is made to join to any previous material.

Since crash-recording mode destroys any CTL information that might already be on the tape at the start and end of the recording, the playback just at the start

and end of the recording will have picture disturbance.

Crash record is usually used to make the first recording on a blank tape.

Assemble Starts to record in assemble edit mode. New video, audio tracks, linear timecode and control track are recorded and joined to any previous material.

Since, assemble recording mode destroys any CTL information that might already be on the tape at the end of the recording, playback at the end of the recording will have picture disturbance.

Insert Starts to record in the Insert edit mode. Insert allows you to define which video and audio tracks are selected using the jog/shuttle key and the wheel. Existing control track and linear timecode are preserved and playback discontinuities at the start and end of the recording are minimised.

The tracks are displayed as follows:

```
V 1 2 T 4      1 2 3 4 5 6 7 8
* * * *      * * * * * * * *
```

The * indicates that the track is enabled. The first 4 tracks labelled 1,2,T and 4 are audio analogue tracks and the second set of tracks 1 - 8 are digital audio tracks.

The Record start and end points are made with clean edit points, therefore enabling replay at the start and end of the recording.

Rec only edit

NO or YES

NO ^{DEF}

Description: If editing is to be done using only a record VTR (channels REM 2 and above)

Using the Menu system

for recording "live" signals, then set to YES. This leaves the player channel (REM 1) free to mark and recall cues. When set to NO the player channel can be used as an edit source VTR. Note: it is not necessary to use a source VTR in this mode, but cues will not be available.

Cue mode

Cue & Stop, Cue & Play Stop ^{DEF}

Description: Effects the cueing of the connected VTRs.

Cue & Stop Cues the VTR and goes into still.

Cue & Play Enters the play mode automatically once an operator has initiated the CUE command.

Stop at

Off, End, Out Off ^{DEF}

Description: End, stores the T/C at the point the recorded channel was stopped (less 6 frames), when replayed in PLAY or VAR mode the controller will stop the VTR at this T/C before the playback overruns into unwanted black. Out stops the playback on the out point of a cue in playback mode.

Fast Cue

NO or Yes NO ^{DEF}

Description: Some VTRs cue tape very slowly using the standard cue command. Fast cue mode allows fast forward and rewind commands in CUE mode. These commands are used for cueing until the tape position is within a few seconds of the cue point, then the cue command is issued.

Mark Increment

Off, In, Out, Both

OFF ^{DEF}

Description: Describes the action of the mark keys. Marking next cues can be made to increment after the In key is pressed or the out key or both

Rew/FF Latch

Cue controller only

Off, On

OFF ^{DEF}

Description: Prevents the fast forward and rewind buttons from latching down.

Rec Inhibit VTRx

NO or Yes

NO ^{DEF}

Description: Inhibits recording on selected channel.

Label

XXXX

VTR1 ^{DEF} or -R1- ^{DEF}

Description: Changes the label displayed in the bottom right hand corner of the display when not in MENU. A large character set is available to make most 4 character labels. Turn wheel to select a character on the display then press and hold the jog key, and turn the wheel to select the new character.

Lock (Kbd)

NO or YES

NO ^{DEF}

Description: Locks all the transport controls except PLAY, VTR selection and MENU.

Lock VTR

Cue controller only

NO or YES

NO ^{DEF}

Description: Locks the PLAY and RECORD transport controls only. Note: the controller must be in PLAY or RECORD first before turning this mode on.

Using the Menu system

Edit Delay

nn frms 5 frames ^{DEF}

Description: 1. Corrects the delay time from sending the RECORD command to the VTR until recording starts.
2. Sets the amount of time the VTR will cue back after an auto cue.

Start Delay

nn frms 0 frames ^{DEF}

Description: Corrects the delay from sending the PLAY command to the player VTR.

Jog Rate, Var Rate and Sht (Shuttle)Rate

Min, Slow, Norm, Fast, Max Normal ^{DEF}

Description: Changes the reaction time of the wheel input to the tape being replayed to compensate for tape, disk and operator preference. For example if the Jog speed is set to Min, then more than one complete turn of the wheel is required to advance a frame.

| Setting | Jog reaction time | Shuttle range | Var range |
|---------|---------------------|-----------------------|------------------------|
| Min | Minimum | +/- 1.0 | +/- 0.25 |
| Slow | Slow | +/- 2.0 | +/- 0.33 |
| Norm | Norm ^{DEF} | +/- 15 ^{DEF} | +/- 0.5 |
| Fast | Fast | +/- 24 | +/- 1.0 ^{DEF} |
| Max | Maximum | +/- 50 | +/- 2.0 |

Clear Cues

NO, YES

Description: Clears all the cues from the memory of the controller.

Clear Config

NO, YES

Description: Restores the factory default conditions.
See all items marked as ^{DEF}.

Trig A, Trig B, Trig C, Trig D

None, Stop, Rec, Play, Rew, Fwd, Cue In, Mark In, Mark Out, VTR, Out-5s, Out-0s, Tally None ^{DEF}

Description: A total of 4 individual trigger inputs and 4 outputs that can be assigned to any VTR, to set an event to occur.

When another device is connected to the 25-way 'D' type connector of the GPI option, the controller can provide a tally out signal (mimics the LEDs on the control panel) and accept a tally in signal (mimics the keys on the control panel) as programmed.

The ON-AIR tally is set from Trig A only.

Auto cue

Off, Wheel (T-Bar or Both "s" version only) Off ^{DEF}

Description: Turning the wheel will drop the VTR/DDR into jog, regardless of the state, ie record, play, etc. Moving the T-Bar will cause the VTR/DDR to go into Variable speed mode in any state other than record.

Beeper

Off, On, Error On ^{DEF}

Description: Turn the beeper function on/off.

Vid Std

PAL, NTSC PAL ^{DEF}

Description: Sets the T/C to run on either PAL or NTSC

Using the Menu system

standard

Wrap marks

PAL, NTSC

NO ^{DEF}

Description: No more marks can be stored when the maximum number of cues has been stored. Turn on to wrap around and overwrite cue points.

Disk

Sport version controller only

NO, YES

NO ^{DEF}

Description: This special mode sets half the controller ports to be playback and half to be record for DDRs that are record and playback devices.

Auto Group

Sports version controller only

NO, YES

NO ^{DEF}

Description: Enable or disable auto grouping of playback channels in DISK mode

EE mode auto or full

AUTO, FULL

AUTO ^{DEF}

Description: Change the EE function from automatic to manual.

Wheel SW Enable

NO, YES

NO ^{DEF}

Description: Enables or disables wheel switch

5 Touble Shooting

The following section lists commonly asked questions and their solution:

Why do labels appear as | | | | when powering the controller for the first time?

This indicates the default settings of the controller need to be stored in the non-volatile memory (see Chapter 4 – Engineering menu - Clear Config).

Are there special connections for a two-machine edit?

Yes. The record VTR MUST be connected to the REM 2 connector and the player MUST be connected to the REM1 connector.

The controller has emitted several short 'beeps' and the remote LED has gone off. What's the problem?

Check that the VTR is not switched into local or that the RS422 communications link is not disconnected.

How do you change settings in the Menu?

The | | key MUST be held down to allow the wheel to change assigned parameter values on the bottom display line.

Why has the Cue function stopped working?

Check that the controller is in Crash Record or Record Inhibit. Cue operations are not available in either Insert or Assemble edit modes.

Touble Shooting

The Mark Out function does not increment the cue number, is this normal?

Yes. The cue point number is only incremented automatically when pressing the Mark IN button.

The display does not indicate Crash Record mode, is this normal?

Yes. Only Insert, Assemble and Inhibit modes are indicated. The controller is in Crash Record mode when the edit mode area of the display is blank.

Where is the tape eject button?

This is the first command available from the Menu.

Refer to Chapter 4, Using the Menu System for further details.

There is no communications to or from the VTR?

Check that the cable adaptors have been made correctly.

6 Addendum

6.1 Summary of functions

| Function | Keys | Description |
|--------------|-------------------------|---|
| Play | [▶] | The VTR will play |
| Play Lock | [▶] and hold | Press and hold for more than 4 second to lock or unlock in playback. (disabled on HT884/8c) |
| Still / Stop | [■] | First press the VTR will be in still mode, second press the VTR will be in stop mode. |
| Standby Off | [■] and hold | The VTR will “spool down” – head drum will stop and tape unthread |
| FFWD | [>>] | Spools the tape forward or together with play for latched forward. Menu setting in controller |
| Latched FFWD | [>>] + [▶] | |
| RWD | [<<] | Spools the tape backward or together with play for latched backward. Menu setting in controller |
| Latched RWD | [<<] + [▶] | |
| Record | [REC] + [▶] | Puts the selected VTR into Record, press play and record together |
| Record Lock | [REC] + [▶] and hold | Press and hold for more than 4 second to lock or unlock in record. (disabled on HT884/8c) |

Addendum

| Function | Keys | Description |
|------------------------|---|--|
| Jogging | ● ○ [□□] or press wheel | Puts the selected VTR into jog mode |
| Shuttleing | ○ ● [□□] or press wheel | Puts the selected VTR into shuttle mode |
| Fixed Shuttle | [▶] + [>>] or [<<] | Fixed shuttle speeds forward and backwards (disabled on HT884/8c) |
| Loop Play | [SHIFT] + [PLAY] or [VAR] | Sets the current cue into loop playback mode. |
| Vari Speed using wheel | ● [VAR] | Puts the selected VTR into variable mode the range depends on the menu setting |
| Vari Speed using T-Bar | [VAR] Next to T-Bar (HT884/8s only) | The VTR will play in variable speed mode, this range depends on the menu settings and if the pre-set variable has been pressed |
| Timecode mode | [T/C] or menu setting in HT884/8c | The timecode display toggles between, LTC, CTL, VITC and AUTO, display |
| Make a Mark In point | [MARK IN] | Creates a Cue in point. Cue No. displayed briefly when button pressed |
| Make a Mark Out point | [MARK OUT] | Creates a Cue out point. Cue No. displayed briefly, when button pressed |

| Function | Keys | Description |
|---|---|---|
| Browsed saved Cues | [SHIFT] + [CUE] or [GOTO CUE No.] and Keypad entry or +/- on HT884/8c | This will allow all saved cues to be viewed. Scroll through using the jog/shuttle wheel. [SHIFT] to exit or [CUE] to cue up |
| Delete a Cue | [MARK IN] or [DEL] | Select the cue as described above, and then hold down MARK IN for more than 1 second. Permanently deletes the cue. Select the Cue and then press the DEL button |
| Advance/retard frames | Press and hold the  key + [+ or -] | Advances or retards the VTR a frame at a time. |
| Pre-Roll back a fixed number of seconds | [Cue] + [<<] | Pre-Rolls the tape by the amount set in the menu setting pre-roll time (disabled on HT884/8c) |
| Post-Roll forward a fixed number of seconds | [Cue] + [>>] | Post-Rolls the tape by the amount set in the menu setting pre-roll time (disabled on HT884/8c) |
| Group Channels | [SHIFT] + [CHANNEL] | Hold down the shift button and the channel buttons that are to be grouped together |
| Go to a Timecode | [GOTO T/C] + [Keypad] + [CUE] | Will cue the controller to the entered timecode |
| Go to a Cue | [GOTO CUE No] + [Keypad] + [CUE] | Will cue the controller to the entered cue point |

Addendum

| Function | Keys | Description |
|---|--|--|
| Use the T-Bar to shuttle | [T-BAR SHUTTLE] and move T-Bar | Allows the T-bar to be used to shuttle instead of the jog wheel |
| Pre-set variable range T-Bar | [PRESET VARIABLE] + [VAR] and move T-Bar | The VTR will go into variable playback, using the variable range set in the menu |
| Freeze during Slow Motion | [STILL ■] | The selected VTR playback will freeze the VTR during the slow motion playback |
| Eject the tape | [MENU] | Eject must be selected from the menu using the jog wheel |
| Live/Playback (Slow motion controller only) | [REC] | Switch between live and playback (Disk mode must be on) |

6.2 Outline dimensions

The base model HT88x has the following outline dimensions:

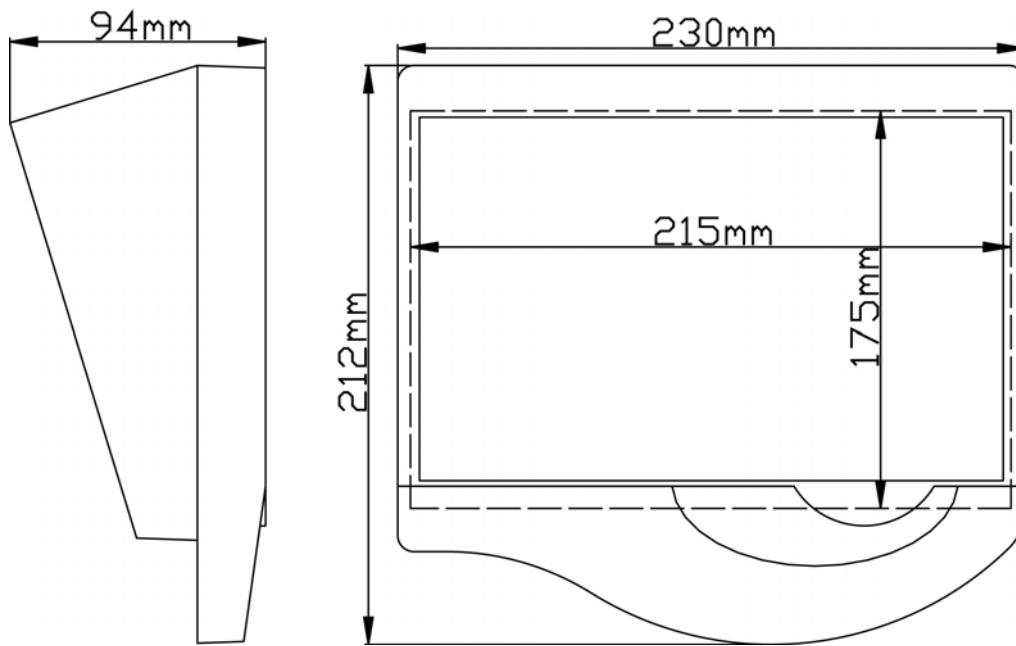

HT88x Outline dimensions

Models with a direct entry key pad and/or direct entry keypad and fader arm have the following outline dimensions:

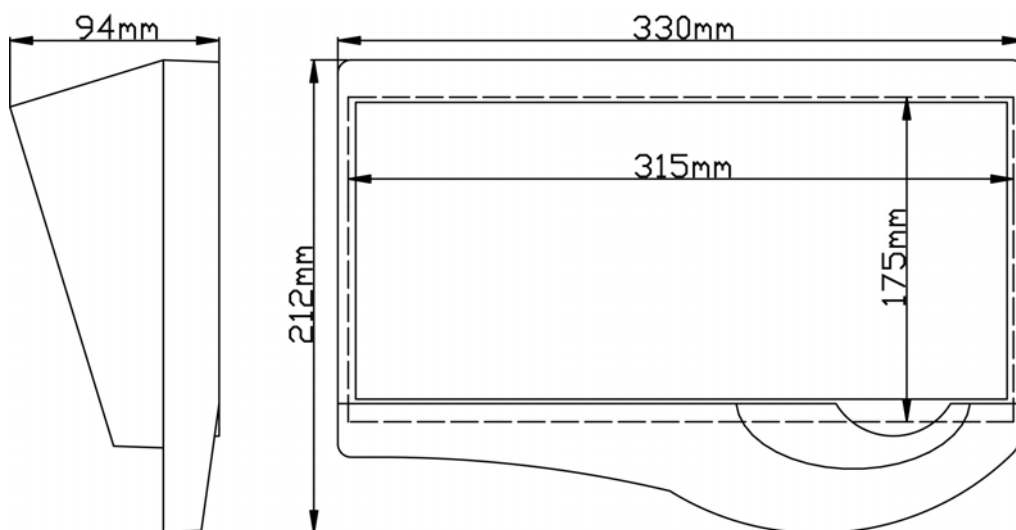

HT88x/c/s Outline dimensions

6.3 Disassembly

These instructions are provided mainly to allow controller software firmware to be upgraded.

CAUTION: DURING DISASSEMBLY, ALWAYS ENSURE THAT AC POWER IS DISCONNECTED FROM THE EQUIPMENT. ONLY SUITABLY QUALIFIED ENGINEERS SHOULD CARRY OUT MAINTENANCE.

Access to the main PCB is very simple, proceed as follows:

- Loosen and remove the 4 screws in the base of the case
- Carefully remove lid a little way and then unplug the ribbon cables connecting the front panel to the base
- Store the lid somewhere safe

Note: Care should be taken to ensure that the shorter screws are replaced in the same position.

Removing the main PCB

In the unlikely event that the main PCB requires replacement proceed as follows:

- Remove the IEC mains retaining clip from the rear panel
- Loosen and remove the 2 IEC mains screws from the rear panel

Now carefully remove the two PCB fixing screws from the front edge of the main PCB and carefully pull forward and lift out the main PCB from the case

Replacing the PCB

When replacing the PCB ensure that it is correctly located in the rear panel before tightening the two screws at the front edge of the PCB.

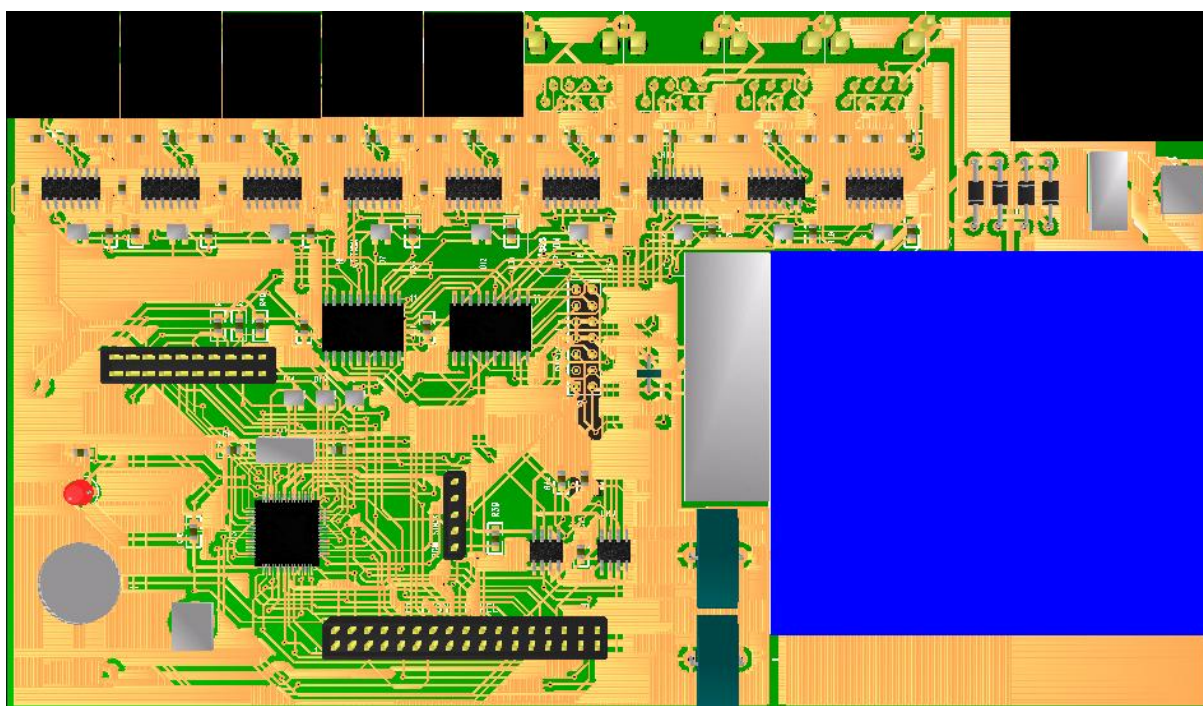

Mother Board PCB

Software Updates

Download the software update wizard actiV8 from the Hi Tech Systems web site, and contact Hi Tech Systems for the latest software version.

6.4 Cable pin out reference

The following diagrams are provided for those wishing to make their own cables.

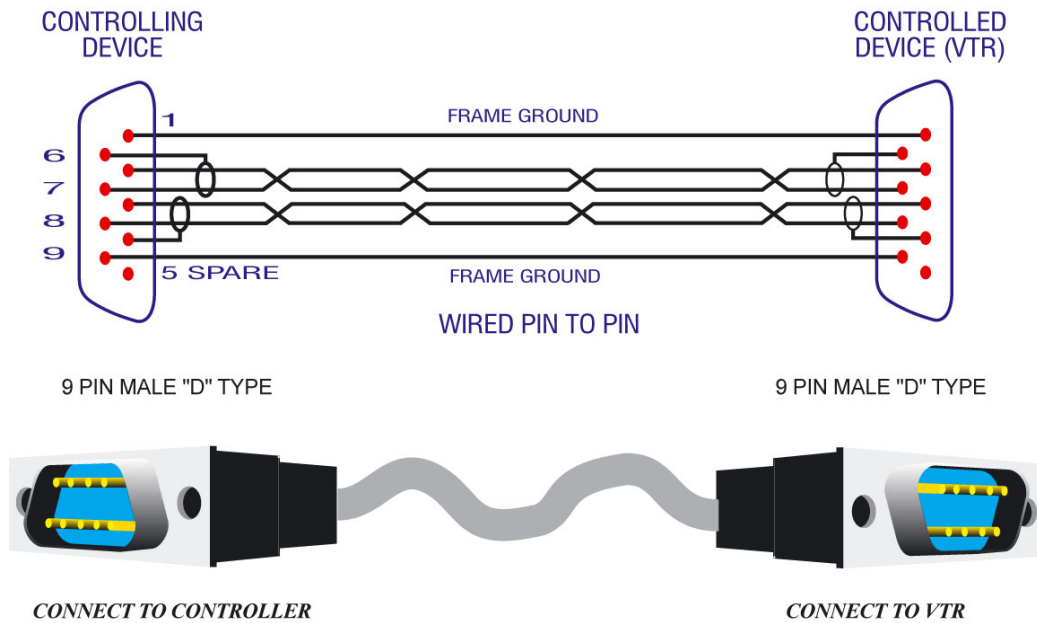

Standard RS422 cable

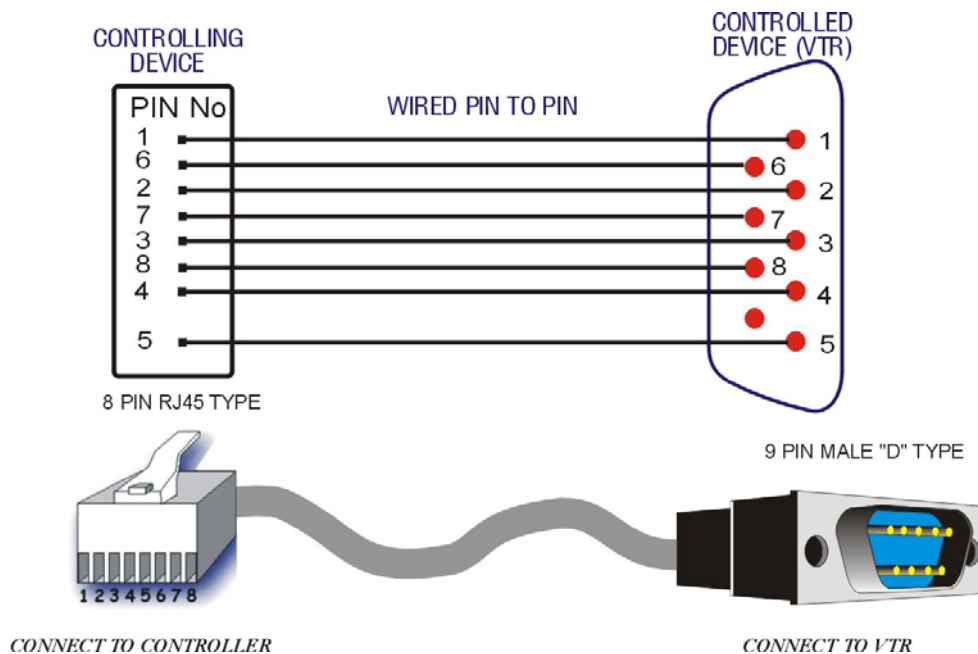

RJ45 to D type - RS422 cable

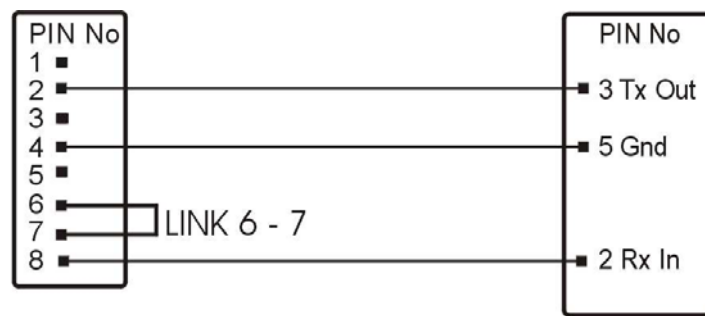

8 PIN RJ45 PLUG

9 PIN "D" TYPE SOCKET'S

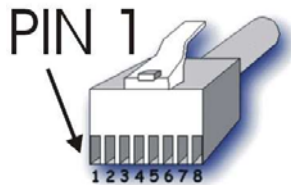

CONNECTION TO
CONTROLLER
USING RJ45 CONNECTOR

CONNECTION TO
RS232 ON PORT
ON COMPUTER

RJ45 to D type – RS232 cable

Making a software upgrade serial cable

Notes on PC serial connectors

Some computers, particularly laptops have odd earth arrangements on the RS232 connector, making the download problematic. If possible, use a desktop PC for performing s/w updates.

Addendum

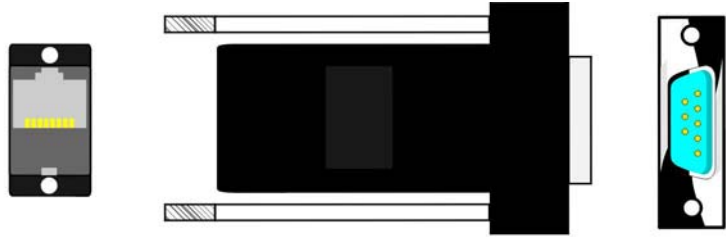

| PIN | Description | Colour (shielded) | Colour (un-shielded) |
|-----|-------------|-------------------|----------------------|
| 1 | Chassis Gnd | BLUE | 1 BLACK |
| 2 | Rx A data | ORANGE | 2 YELLOW |
| 3 | Tx B data | BLACK | 3 ORANGE |
| 4 | Tx Gnd | RED | 4 RED |
| 5 | N.C | GREEN | 5 GREEN |
| 6 | Rx Gnd | YELLOW | 6 BROWN |
| 7 | Rx B data | BROWN | 7 GREY |
| 8 | Tx A data | WHITE | 8 BLUE |

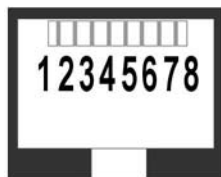

VIEW FROM THE OUTSIDE

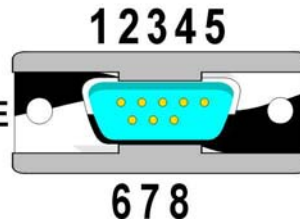

Making the RJ45 to RS422 *male* adapters

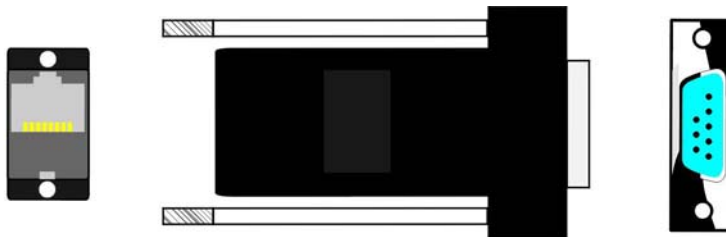

| PIN | Description | Colour (shielded) | Colour (un-shielded) |
|-----|-------------|-------------------|----------------------|
| 1 | Chassis Gnd | BLUE | 1 BLACK |
| 2 | Rx A data | ORANGE | 2 YELLOW |
| 3 | Tx B data | BLACK | 3 ORANGE |
| 4 | Tx Gnd | RED | 4 RED |
| 5 | N.C | GREEN | 5 GREEN |
| 6 | Rx Gnd | YELLOW | 6 BROWN |
| 7 | Rx B data | BROWN | 7 GREY |
| 8 | Tx A data | WHITE | 8 BLUE |

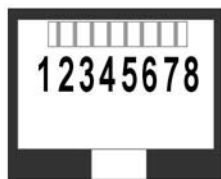

VIEW FROM THE OUTSIDE

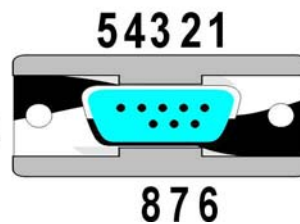

Making the RJ45 to RS422 *female* adapters

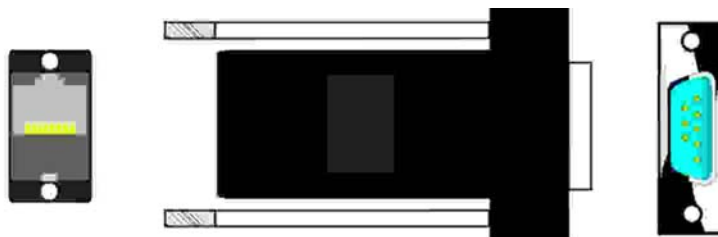

| PIN | Description | Colour (shielded) | Colour (un-shielded) |
|-----|-------------|-------------------|----------------------|
| 1 | Chassis Gnd | BLUE | 1 BLACK |
| 2 | Rx A data | ORANGE | 8 YELLOW |
| 3 | Tx B data | BLACK | 7 ORANGE |
| 4 | Tx Gnd | RED | 4 RED |
| 5 | N.C | GREEN | 5 GREEN |
| 6 | Rx Gnd | YELLOW | 6 BROWN |
| 7 | Rx B data | BROWN | 3 GREY |
| 8 | Tx A data | WHITE | 2 BLUE |

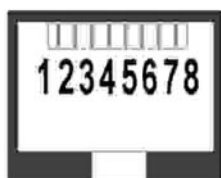

VIEW FROM THE OUTSIDE

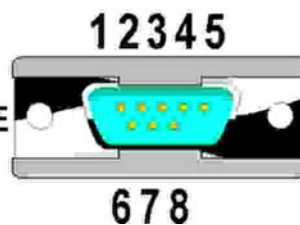

Making the RJ45 to RS422 loop adapters

7 Specification

Control ports

Communication Format: RS-422-A

Communication Channel: Full Duplex

Data Signalling Rate: 38.4 Kb/s (K bits per second)

Communication Protocol: SONY 9 pin RS422

Serial connectors: RJ45 – 8 pin sockets

VTRs controlled: VTRs that support the Sony RS422 9 pin protocol

Power

Mains input: Fused IEC connector

Voltage: 90 to 260 VAC 47-63Hz selected via reversible fuse holder

Power consumption: Less than 10 watts

Optional GPI module

GPI / Extension: 25 pin "D" 25 socket

General

Operating Temp: 0 - 35 Deg C